



# NEW ITEMS 2024

LOCOMOTIVES AND WAGONS IN GAUGE H0 AND N





## WELCOME TO THE BRAWA NEW PRODUCTS FOR 2024!

NUMEROUS MODELS IN H0 AND N GAUGES  
WITH AN ABUNDANCE OF EXQUISITE DETAILS

This New Items Brochure presents a large number of new BRAWA locomotives and wagons in H0 and N gauges. Explore around 290 new types, including many fresh and exciting designs.

In H0 gauge, the BR 44 Freight Locomotive with oil tender is a real "jumbo" on the rails. This steam locomotive generated an extremely strong tractive force and was primarily used in heavy freight services. The new designs also include the streamlined express train



coach of Group 39, totaling 36 models representing various railway companies.

Eight models of the 6-axle Zzd Gas Tank Wagons, which were produced by Fuchs Waggonfabrik A.G. in the 1940s, are now available in H0 as new types for the DRG, DB and DR.

The Shimmns Sliding Roof Wagons are a real highlight – the BRAWA range now includes 17 different variants of this iconic design.

The Omm55 Open Freight Cars played a crucial role in European goods traffic and were often used to transport coal. The new BRAWA models are available in numerous variants that saw service with the DB as well as various European railway companies.

The 2024 range will once again include numerous H0 Freight Cars with advertising imprints in limited editions, and the Z[P] "Storck" Tank Car will be available as part of a special Easter promotion.

In N gauge, for example, BRAWA will launch the TWINDEXX VARIO® Double-deck Train from NAH.SH (3-unit), which will also be available as a digital version with sound and switchable light functions.

We hope you enjoy discovering your new favourite models! You can also look forward to the upcoming issues of the BRAWA News Express, in which we will unveil many additional models throughout the year!



JETZT ENTDECKEN! [WWW.BRAWA.DE](http://WWW.BRAWA.DE) DISCOVER NOW!

## H0

### GAUGE H0

- 02 Steam locomotives
- 08 Electric locomotives
- 12 Diesel locomotives
- 16 Rail cars
- 24 Passenger coaches
- 45 Freight cars

## N

### GAUGE N

- 68 Rail cars
- 70 Diesel locomotives
- 71 Passenger coaches

## H0

### LIMITED SPECIAL MODELS H0

- 72 Freight cars "Traditional brands"
- 74 Milk cars
- 75 Freight cars "Automotive"
- 76 Freight cars "Beer brands"
- 77 Freight cars "Nostalgia of GDR"
- 77 Special model for easter 2024
- 78 Special models "Skylines"





## THE "JUMBO" FOR HEAVY FREIGHT CARS – NOW WITH OIL TENDER

STEAM LOCOMOTIVE BR 44  
WITH OIL TENDER



Like the German Federal Railway (Deutsche Bundesbahn or DB) in the West, the East German National Railway (Deutsche Reichsbahn or DR) was also continuously striving to improve its fleet and increase its efficiency. By the early 1950s, a significant number of BR 44 locomotives had been converted from coal to coal dust firing, enabling a 10% increase in boiler output. Even greater performance gains were realised with the subsequent transition to oil firing. The National Railway conducted initial trials of oil firing on locomotive 44 195. After being converted to oil firing, this locomotive was dispatched to the testing facility in Halle, where it underwent thorough operational assessments.

Following favourable test results, the National Railway authorised the conversion of an additional 96 locomotives to oil firing at the Meiningen

maintenance depot between 1963 and 1967. The 2'2' T34 oil tenders were equipped with the distinctive square 13.5 m<sup>3</sup> heavy oil tank and a closed rear bulkhead to the cab. The latter improved the working conditions on the engineer's platforms, especially during reverse travel. Since the DR only filled its oil tanks from the top, there was no need for an external riser pipe to bunker the fuel.

The new firing system made the 44 Oil virtually irreplaceable within the DR's fleet. Of the 102 BR 44 locomotives still in operational condition in 1974, 94 were oil-fired and mainly distributed among the Eberswalde, Nordhausen, Saalfeld, Sangerhausen and Wittenberge railway depots. The BR 44 series remained in service until late 1981, when it was retired rather abruptly as a result of the second oil crisis.





© G. MOLL

**Freight Locomotive BR 44 DR**  
Road no. 44 0101-4; Bw Sangerhausen

Order no. <b>70116</b>	Analog BASIC+	20	20	Order no. <b>70118</b>	Digital EXTRA	20	20	D&H
IV NEM	261	Rmin 420	PluX 22	4				DR DEUTSCHE REICHSB EISENB BHN

ADDITIONAL LINES FOR THE BURNER  
VAPOUR SUPPLY

METAL DRIVE AND COUPLING RODS

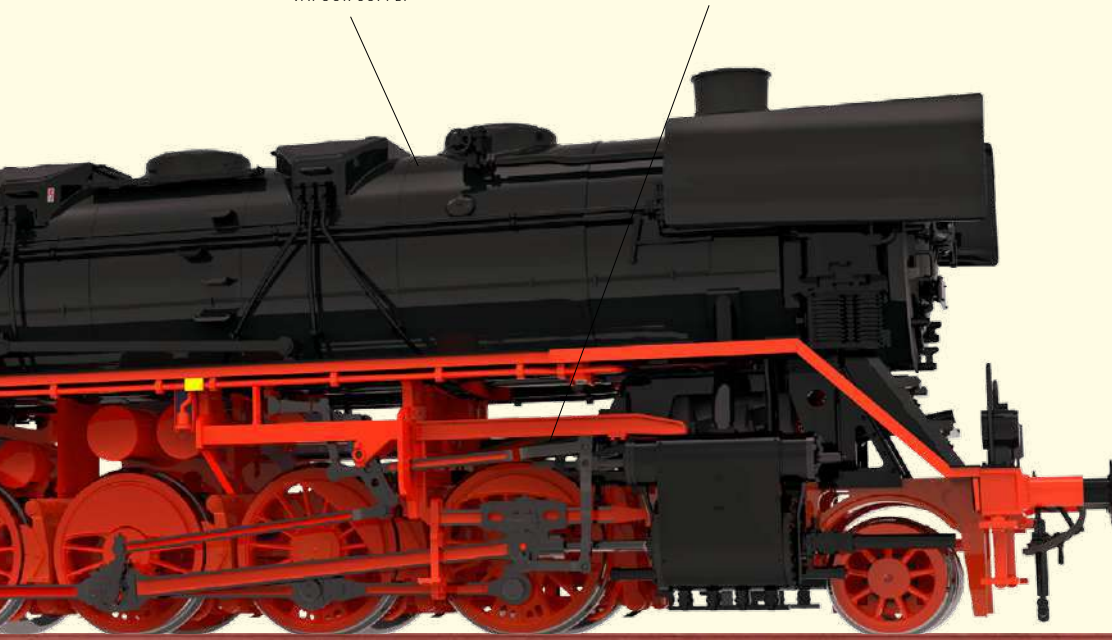

ILLUSTRATION



**Freight Locomotive BR 44 DR**  
Road no. 44 1616; Bw Halle G

Order no. <b>70112</b>	Analog BASIC+	20	20	Order no. <b>70114</b>	Digital EXTRA	20	20	D&H
III NEM	261	Rmin 420	PluX 22	4				DR DEUTSCHE REICHSB EISENB BHN

- Boiler, driver's cab and tender made of high-quality, impact-resistant plastic
- Perforated underframe and spoked wheels in die-cast zinc
- Standard shaft rear with link guide
- Sound decoder, either built in or as a retrofit option
- Smoke generator as a retrofit option
- Close coupling between locomotive and tender
- Drive in the tender
- Single axle bearing
- Perfectly replicated back boilerplate
- Metal drive and coupling rods
- Illuminated driver's cab (Version Digital EXTRA)
- Engine lighting (Version Digital EXTRA)
- Fire flickering (Version Digital EXTRA)





# F-TRAIN MERKUR: NAMED AND CONNECTED BY TRADING CITIES

TRAIN SET F 3/4 "MERKUR" DB

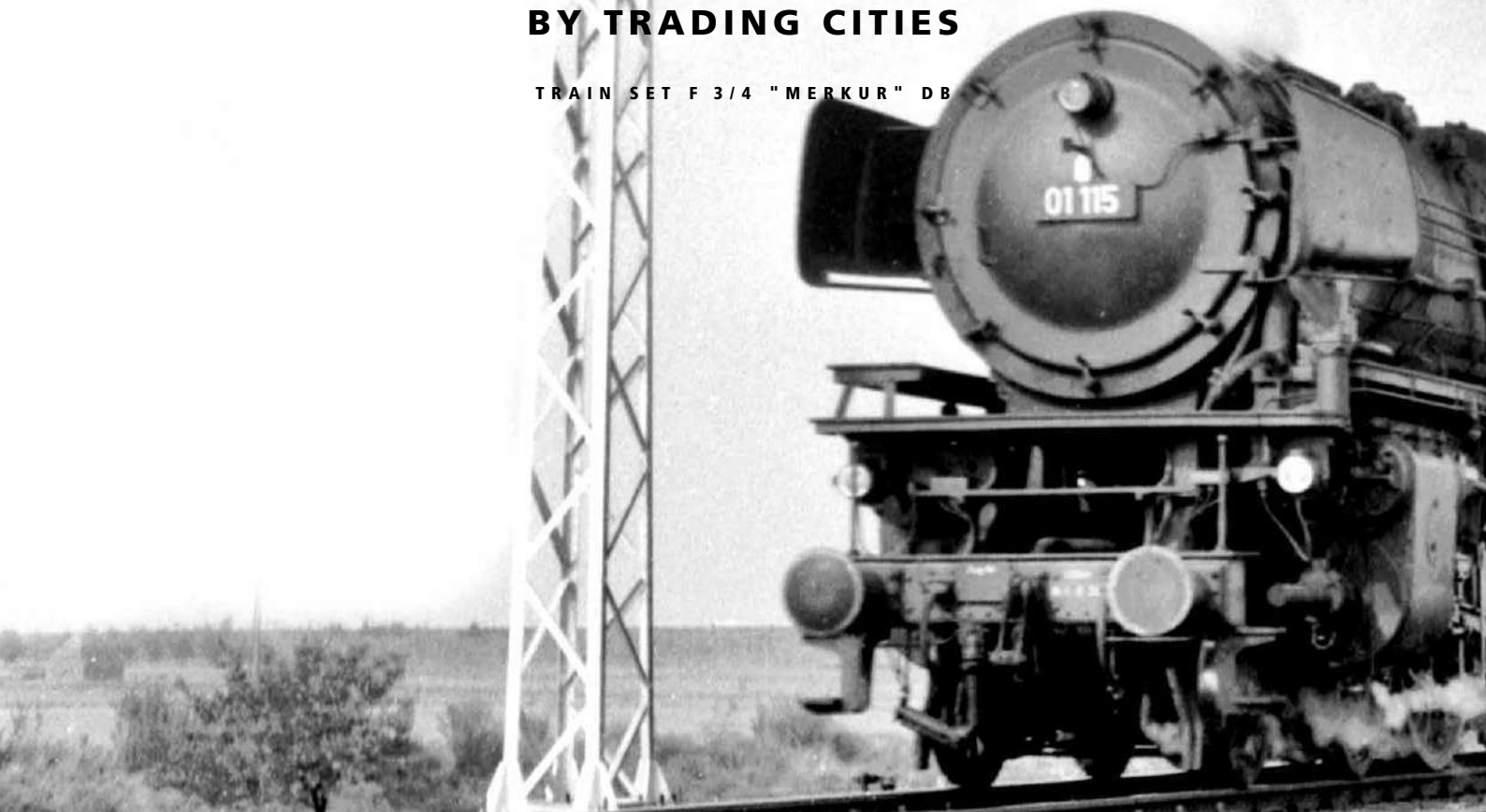

## Train Set F 3/4 "Merkur" DB, Set of 5

Order no.  
**50843**



Order no.  
**50844**



Order no.  
**50845**



- Express Train Locomotive BR 01 DB (Road no. 01 115)
- Express Train Coach A4ümg-54 DB (Road no. 11 998 Ffm)
- Express Train Coach A4ümg-54 DB (Road no. 11 972 Stg)
- Express Train Coach A4ümg-54 DB (Road no. 11 973 Stg)
- Dining Car WR4ü-28/51 DSG (Road no. 12 30)

## Express Train Locomotive BR 01 DB

- Impact resistant body and chassis
- Perforated underframe in die-cast zinc
- Die-cast zinc spoked wheels
- Fine metal drive and coupling rods
- True to era lighting
- Drive in the tender for optimal driving characteristics
- Close coupling between locomotive and tender
- Standard shaft rear with link guide
- True to original boiler rear wall
- Metal axle bearing
- True to scale axle base

## Express Train Coaches A4ümg-54 DB

- True to scale reproduction of the windows
- Wheel sets of type 094/096 with corrugated wheel-discs on both sides
- True to epoch interior fittings
- Interior lighting prepared or built-in
- Elastic rubber bulge
- NEM-standard short coupling
- Alternator on bogie separately mounted
- Extra mounted steps and handrails
- Version with welded roofs
- Compatible with the electrical coupling from BRAWA



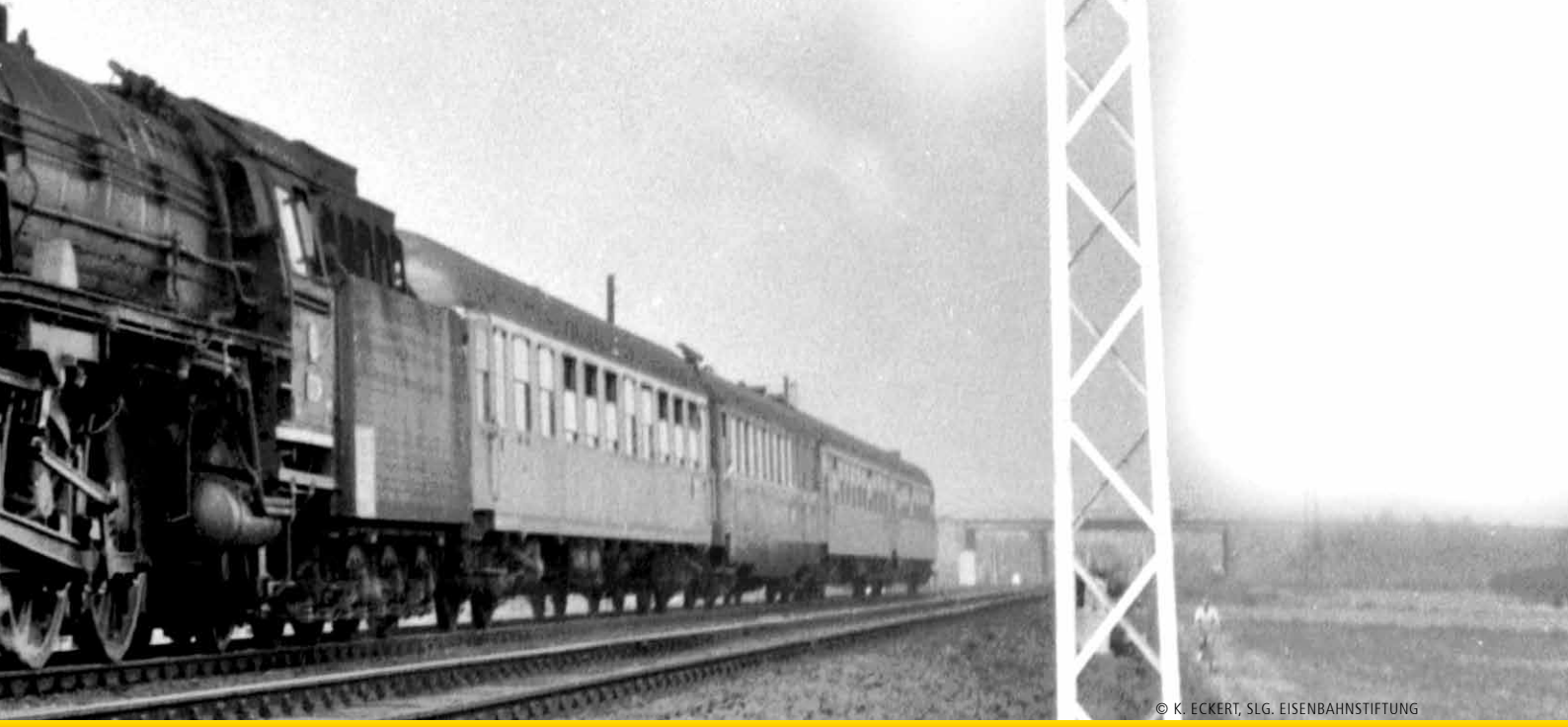

© K. ECKERT, SLG. EISENBAHNSTIFTUNG

Reconstruction in Germany was in full swing when the Federal Railway (DB) launched a network of F-trains for official and commercial transport in the summer of 1951. This internationally recognised move by the DB was a clear response to the emerging trend of private motorised transport and the rapidly growing aviation industry.

From the outset, the F 3/4 train service, which ran from Frankfurt (M) via Cologne to Hamburg and back, was part of this train network. In 1952, these trains were given the name "Merkur" (Mercury), representing the Roman god of trade, merchants and travellers. Over time, the Merkur trains underwent frequent changes in appearance, and the line was also adapted to suit customer needs. Initially, BR

01-series locomotives were used to pull these trains. In subsequent years, vehicles of the series 03, 03.10, 18.5, 18.6, 39, V200 and E18 took turns as train locomotives. From the summer of 1959 to 1961, the F3 line was redirected from Frankfurt via Wiesbaden central station. The rolling stock had already transitioned to the new 26.4 metre-long 1st class carriages including an old-style dining car of the type WR4ü-28, -35 or -39. During the summer of 1959, the 01 149 locomotive from the Darmstadt railway depot was regularly deployed on this section of the line. No doubt driven by economic considerations, the task of pulling the trains was later given to the BR 01 locomotives from the Wiesbaden railway depot, as visually documented by our 01 115.

Functions of the Steam Locomotive BR 01	Analog BASIC+ =	Digital EXTRA =	Digital EXTRA ~
Light change	+	+	+
Fire flickering		+	+
Driver cabin lighting	+ <sup>1)</sup>	+	+
Engine lighting		+	+
Smoke generator		+ <sup>2)</sup>	+ <sup>2)</sup>
Digital interface	PluX22	PluX22	PluX22
Decoder		+	+
Sound		+	+

<sup>1)</sup> function only available in digital mode

<sup>2)</sup> smoke generator as a retrofit option





**Express Train Locomotive BR 01 DRG**  
 Road no. 01 025  
 Rbd Erfurt; Bw Erfurt P

Order no. <b>40968</b>	Analog BASIC*	20	▶	Order no. <b>40970</b>	Digital EXTRA	20	▶	D&H
				Order no. <b>40971</b>	Digital EXTRA	20	▶	D&H
 NEM	275,3	Rmin 360*	PluX 22	4 )	◐	◑	◒	◓



**Express Train Locomotive BR 01 DB**  
 Road no. 01 161  
 BD Hannover; Bw Bremen Hbf

Order no. <b>40972</b>	Analog BASIC*	20	▶	Order no. <b>40974</b>	Digital EXTRA	20	▶	D&H
				Order no. <b>40975</b>	Digital EXTRA	20	▶	D&H
 NEM	275,3	Rmin 360*	PluX 22	4 )	◐	◑	◒	◓



**Express Train Locomotive BR 01 DR**  
 Road no. 01 205  
 Rbd Erfurt, Bw Erfurt P

Order no. <b>40976</b>	Analog BASIC*	20	▶	Order no. <b>40978</b>	Digital EXTRA	20	▶	D&H
 NEM	275,3	Rmin 360*	PluX 22	4 )	◐	◑	◒	◓

\* Navigable minimum radius: The models of BR 01 are technically suitable for R 360. For best driving characteristics we recommend the use on R 420.







Order no. **40980** Analog BASIC+ 20 20 D&H

Order no. **40982** Digital EXTRA 20 20 D&H

Order no. **40983** Digital EXTRA 20 20 D&H



**Express Train Locomotive  
BR 001 DB**  
Road no. 001 168-4  
BD Regensburg; Bw Hof



Order no. **40984** Analog BASIC+ 20 20 D&H

Order no. **40986** Digital EXTRA 20 20 D&H

Order no. **40987** Digital EXTRA 20 20 D&H

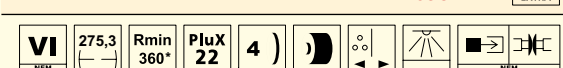

**Express Train Museum Locomotive  
BR 01 association "Pacific 1202"**  
Road no. 01 202

Functions of the Steam Locomotives BR 01	Analog BASIC+ =	Digital EXTRA =	Digital EXTRA ~
Light change	+	+	+
Fire flickering		+	+
Driver cabin lighting	+ <sup>1)</sup>	+	+
Engine lighting		+	+
Smoke generator		+ <sup>2)</sup>	+ <sup>2)</sup>
Digital interface	PluX22	PluX22	PluX22
Decoder		+	+
Sound		+	+

<sup>1)</sup> function only available in digital mode

<sup>2)</sup> smoke generator as a retrofit option



- Impact resistant body and chassis
- Perforated underframe in die-cast zinc
- Die-cast zinc spoked wheels
- Fine metal drive and coupling rods

- True to era lighting
- Drive in the tender for optimal driving characteristics
- Close coupling between locomotive and tender
- Standard shaft rear with link guide

- True to original boiler rear wall
- Metal axle bearing
- True to scale axle base





# FROM "HIMMELREICH" TO "HÖLLENTAL". SOON ON YOUR TRACKS

TRAIN SET "HÖLLENTALBAHN" DB



## Train Set "Höllentalbahn" DB, Set of 5



Order no.  
**50894**



Order no.  
**50895**



Order no.  
**50896**



- Electric Locomotive BR E44w DB (Road no. E44 176)
- Passenger Coach ABie-34 DB (Road no. 39 025 Kar)
- Passenger Coach Bie-33 DB (Road no. 98 083 Kar)
- Passenger Coach Bie-33 DB (Road no. 98 101 Kar)
- Luggage Car Pwie-30 DB (Road no. 114 832 Kar)

Additional information: All coaches without lighting and decoder.

## Electric Locomotive BR E44w DB

- Individually mounted handle bars
- Metal handle bars
- Individually mounted metal roof lines
- Metal wheels
- Metal frame
- Bogie with three-point support
- Multi-part roof-fittings
- Individually mounted windscreen wiper
- Metal pantographs (mechanical)
- Detailed chassis
- 5-pole motor
- True to era lighting
- Drivers cabin lighting
- Etched fan grills

## Luggage Car Pwie-30 DB (New mould)



The Höllentalbahn (from Freiburg central station via Neustadt/Schwarzwald to Donaueschingen) rightfully ranks among the most impressive stretches of railway in Germany thanks to its breathtaking route through the narrow Höllental (Hell Valley) with gradients of up to 57.14%. Today, it is deservedly registered as a culturally significant monument in the Southern Upper Rhine region. In 1933, the line was electrified with a voltage of 20kV and a frequency of 50Hz. At the same time, the fleet was modernised with the BR 85 and E 244 locomotives as well as

Ci-33 and BCi-34 light branch line carriages. It was not until May 1960 that the voltage was switched to the now standard 15kV at 16<sup>2</sup>/3 Hz. Consequently, the E 244 was promptly succeeded by the E44w from the Freiburg railway depot. These vehicles provided the electric traction on the Höllentalbahn and also pulled the typical passenger trains that were used on this line, consisting of various standard secondary line coaches.



Functions of the Electric Locomotive BR E44w	Analog BASIC+ =	Digital EXTRA =	Digital EXTRA ~
Driving function	+	+	+
Light change (white/red)	+	+	+
Upper headlight	+*	+	+
Tail lights separately switchable	+*	+	+
Driver cabin lighting	+*	+	+
Illuminated machine room		+	+
Shunting lights		+	+
Light setting programmable for analogue operation		+	+
Digital interface	PluX22	PluX22	PluX22
Decoder		+	+
Sound		+	+
Energy storage		+	+
Additional information	<ul style="list-style-type: none"> <li>Subsequent conversion from analog to digital via PluX22 interface possible</li> </ul>	<ul style="list-style-type: none"> <li>Optimised light control for driving and shunting modes</li> <li>Latest sound technology and excellent sound quality</li> <li>Compatible with and programmable in all common digital systems (DCC, Motorola, SX1 and SX2)</li> <li>Improved motor and load control</li> <li>Range of functions is designed for digital operation. In analog mode, only the driving function and the light change are available.</li> </ul>	

\* Function in analog mode via switch and in digital mode via function key switchable





# MILESTONE IN ELECTRIC LOCOMOTIVE DEVELOPMENT WITH DETAILS

ELECTRIC LOCOMOTIVE BR 144 DB



## Electric Locomotive BR 144 DB

Road no. 144 086-6 / BD München; BW Rosenheim



A prototype with the designation E44 70 was created at the Siemens-Schuckert Works (SSW) under the general management of Walter Reichel. This prototype later became the E44 001. SSW was able to integrate its experience with electric arcwelding from its production of components for electric generators into locomotive manufacturing, which led to significant savings in materials and manufacturing costs. The prototype's positive test results convinced DRG to further develop the new locomotive type into a universal locomotive. The result was Germany's first two-bogie electric locomotive produced in series, which can safely be categorised as the prototype for the subsequently developed standard electric locomotive of Deutsche Bundesbahn (DB). Due to the war the

delivery of the locomotives, which were registered for 90 km/h, stretched from 1933 into the postwar period, and Henschel only handed over the last one, a E44 187G, to DB on 29 November 1954. The predominant distribution to central and southern Germany led to the fact that approximately 100 locomotives remained in West Germany and around 50 in East Germany after the war. The most conspicuous design changes at DB were the lengthening of the roof shield for accident prevention and the Indusi (inductive traincontrol system) equipment. The last locomotives, however, remained in service until 1985. Of the original 187 locomotives, only 21 still exist today, partially as museum locomotives and as spare parts donors.

Order no.  
**43450**

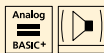

Order no.  
**43452**



Order no.  
**43453**



- Individually mounted handle bars
- Metal handle bars
- Individually mounted metal roof lines
- Metal wheels
- Metal frame
- Bogie with three-point support

- Multi-part roof-fittings
- Metal pantographs (mechanical)
- Individually mounted windscreen wiper
- Detailed chassis
- 5-pole motor
- True to era lighting

- Drivers cabin lighting
- Etched fan grills
- Shunting light (Version Digital EXTRA)
- Engine room lighting (Version Digital EXTRA)



**Electric Locomotive BR 147.5 DB AG**  
Road no. 147 561-5

The product designation TRAXX 3 from Bombardier Transportation reflects the continued development of the well-known TRAXX 2 locomotives of the 146 and 185 series. The new vehicles include the 147 series, for passenger and long-distance traffic, and the 187 series for goods traffic. In addition to the changed appearance of the front, which now consists largely of GRP parts, customers can order a last-mile module for the TRAXX 3 platform if desired. This allows these vehicles, which are designed as electric locomotives, to run on short sections of track or perform shunting work independently with a diesel engine or under battery power. The first test drives with the new TRAXX 3 locomotives took place shortly after their unveiling in 2011. Thanks to many smaller and some large orders, including a framework agreement for 450 units with DB AG, well over 200 locomotives of the TRAXX 3 platform have been delivered to customers to date and are currently in service throughout Europe.



Order no. <b>43834</b>	Analog BASIC+	Order no. <b>43836</b>	Digital EXTRA
		Order no. <b>43837</b>	Digital EXTRA

--	--	--	--	--	--	--	--	--

**Model:** LED lighting; extra mounted windscreen wiper; true to original gearbox; improved power consumption; etched front steps; NEM-standard short-coupling; detailed buffer screed & roof; driver's cab light; PluX22 interface



Order no. <b>43842</b>	Analog BASIC+	Order no. <b>43844</b>	Digital EXTRA
		Order no. <b>43845</b>	Digital EXTRA

--	--	--	--	--	--	--	--	--

**Electric Locomotive BR 187**  
**RheinCargo**  
Road no. 91 80 6187 074-0

Functions of the TRAXX 3	Analog BASIC+ =	Digital EXTRA =	Digital EXTRA ~
Driving function	+	+	+
Light change	+	+	+
Tail lights separately switchable	+*	+	+
Driver cabin lighting	+*	+	+
Shunting lights	+*	+	+
Long-distance headlights	+*	+	+
Destination indicator (model dependent)	+	+	+
Digital interface	PluX22	PluX22	PluX22
Decoder		+	+
Sound		+	+
<b>Additional information</b>	<ul style="list-style-type: none"> <li>Subsequent conversion from analog to digital via PluX22 interface possible</li> <li>Optimised light control for driving and shunting modes</li> <li>Latest sound technology and excellent sound quality</li> <li>Compatible with and programmable in all common digital systems (DCC, Motorola, SX1 and SX2)</li> <li>Improved motor and load control</li> </ul>		

\* Function only available in digital mode





Diesel Locomotive BR V100 DR  
Road no. V100 012

Order no. <b>41712</b>	Analog BASIC*		Order no. <b>41713</b>	Digital EXTRA		Digital Coupling	Energy Storage	D&H
	160 	Rmin 360*	PluX 22	2 )				



Diesel Locomotive BR 115 DR  
Road no. 115 445-9

Order no. <b>41714</b>	Analog BASIC*		Order no. <b>41715</b>	Digital EXTRA		Digital Coupling	Energy Storage	D&H
	160 	Rmin 360*	PluX 22	2 )				





**Diesel Locomotive BR 203 DB AG**  
Road no. 203 315-7

Order no. <b>41708</b>	Analog BASIC+	Order no. <b>41710</b>	Digital EXTRA	Digital Coupling	Energy Storage	D&H
		Order no. <b>41711</b>	Digital EXTRA	Digital Coupling	Energy Storage	D&H



**Diesel Locomotive BR 203 STRABAG**  
Road no. 203 841-2

Order no. <b>41704</b>	Analog BASIC+	Order no. <b>41706</b>	Digital EXTRA	Digital Coupling	Energy Storage	D&H
		Order no. <b>41707</b>	Digital EXTRA	Digital Coupling	Energy Storage	D&H

Functions of the Diesel Locomotive BR V100 / 203	Analog BASIC+ =	Digital EXTRA =	Digital EXTRA ~
Driving function	+	+	+
Light change (white / red)	+	+	+
Tail lights separately switchable	⊕ <sup>1)</sup>	+	+
Driver cabin lighting	⊕ <sup>2)</sup>	+	+
Shunting lights	⊕ <sup>2)</sup>	+	+
Light setting programmable for analogue operation		+	+
Digital interface	PluX22	PluX22	PluX22
Decoder		+	+
Sound		+	+
Energy Storage		⊕ <sup>3)</sup>	⊕ <sup>3)</sup>
Digital coupling		+	+
Locomotive Card			+
Additional information	<ul style="list-style-type: none"> <li>Subsequent conversion from analog to digital via PluX22 interface possible</li> <li>Optimised light control for driving and shunting modes</li> <li>Latest sound technology and excellent sound quality</li> <li>Compatible with and programmable in all common digital systems (DCC, Motorola, SX1 and SX2)</li> <li>Improved motor and load control</li> <li>Range of functions is designed for digital operation. In analog mode, only the driving function and the light change are available.</li> </ul>		

1) Tail light can be switched off in analog mode via switch (on the blind plug); digitally switchable with decoder  
 2) Function only available in digital mode  
 3) Storage capacitor for interruption-free travel in sections without current or on soiled tracks





**Diesel Locomotive Gravita®  
BR 265 DB AG**  
Road no. 92 80 1265 009-1

Order no. <b>70104</b>	Analog BASK*		Order no. <b>70106</b>	Digital EXTRA		Digital Coupling		Energy Storage	D&H
			Order no. <b>70107</b>	Digital EXTRA		Digital Coupling		Energy Storage	D&H
VI NEM	194,3	Rmin 360	PluX 22	2 )					
									DB



**Diesel Locomotive Gravita® BR 261 SGL**  
Road no. 92 80 1261 309-9

After a short development time, Voith Turbo Lokomotivtechnik presented the first sample of the Gravita® family at InnoTrans 2008. Five different performance classes are projected, from the four-axle Gravita® 20BB to the "chicks", which go by the name Gravita® 5BB and which have only two axles. Although the vehicle had only existed as a prototype and was not yet widely tested, DB Schenker decided on more than 130 locomotives for the Gravita® 10BB in its 2007 bid invitation. By now, the units of the Gravita® 10BB are in use on German rail tracks. The designated DB machines are produced and in use nationwide under the series

designation BR 260. Apart from Northrail, another 5 locomotives went to Switzerland. Continuing this success, the larger sister in this series, the Gravita® 15D, was shown in Berlin in 2010. Although only 1.2 m longer than the Gravita® 10BB, it produces up to 1,800kW, making it as suitable for line service as it is for shunting. All locomotives built by Voith Turbo Lokomotivtechnik are also suited for multi-led traction with each other.

Order no. <b>42778</b>	Analog BASK*		Order no. <b>42780</b>	Digital EXTRA		Digital Coupling		Energy Storage	D&H
			Order no. <b>42781</b>	Digital EXTRA		Digital Coupling		Energy Storage	D&H
VI NEM	180,7	Rmin 360	PluX 22	2 )					SGL







**Diesel Locomotive Gravita® BR 261**  
**Städtische Häfen Hannover**  
 Road no. 92 80 1261 312-3

Order no. <b>70108</b>	Analog BASIC+	Order no. <b>70110</b>	Digital EXTRA	Digital Coupling	Energy Storage	D&H
		Order no. <b>70111</b>	Digital EXTRA	Digital Coupling	Energy Storage	D&H

VI NEM 180,7 Rmin 360 PluX 22 2 )



**Functions of the Gravita® 10 BB and 15 D**

	Analog BASIC+ =	Digital EXTRA =	Digital EXTRA ~
Driving function	+	+	+
Light change	+	+	+
Tail lights separately switchable	+ <sup>1)</sup>	+	+
Driver cabin lighting	+ <sup>1)</sup>	+	+
Shunting lights	+ <sup>1)</sup>	+	+
Long-distance headlights	+ <sup>1)</sup>	+	+
Light setting programmable for analogue operation	+	+	+
Digital interface	PluX22	PluX22	PluX22
Decoder	+ <sup>+</sup>	+	+
Sound		+	+
Energy storage		+ <sup>2)</sup>	+ <sup>2)</sup>
Driven fan motor		+	+
Digital Coupling (NEM-standard coupling)		+	+
Locomotive Card			+

**Additional information**

<sup>1)</sup> Function only available in digital mode

<sup>2)</sup> Storage capacitor for interruption-free travel in sections without current or on soiled tracks

- Optimised light control for driving and shunting modes
- Subsequent conversion from analogue to digital via PluX22 interface possible
- Easy decoder installation without extensive reprogramming; all significant values for the control of the light for instance can be found on the main circuit board and do not depend on the installed decoder

- Optimised light control for driving and shunting modes
- Latest sound technology and excellent sound quality
- Compatible with and programmable in all common digital systems (DCC, Motorola, SX1 and SX2)
- Improved motor and load control





Order no.  
**44744**



Order no.  
**44746**



**Diesel Railcar BR VT137 DRG**  
Road no. 137 354

Order no.  
**44747**



TRUE TO ORIGINAL  
BOGIES

PASSENGER COMPARTMENT  
LIGHTING



### Diesel Railcar BR 660 and Trailer 945 DB

Road no. 660 507-5 / 945 851-4

After the railcars were assumed by the recently-founded German Federal Railway (DB), several design changes were made in the 1950s in order to retrofit the vehicles that now bore the designation VT60.5 for the upcoming service period. At the Friedrichshafen repair centre, the engines were replaced with 330 HP MAN machines that were already used in small locomotives from service group III. The upholstery of the 3rd class which was upgraded to become 2nd class also increased passenger comfort. Furthermore, many railcars were equipped with modern DB lights during the 1960s in order to improve the view of the track and the conspicuous railcar lights from the National Railway era were removed. Colour changes were also made as the uniform purple for DB diesel vehicles replaced the old DR colour scheme. In contrast to the initial settlement, DB distributed their 31 VT60.5 vehicles to many more operating locations. Consequently, the Rheine, Darmstadt, Stuttgart, Kassel, Frankfurt-Griesheim, Heilbronn, Nuremberg and Friedrichshafen railway depots

became primary application locations. In doing so, six railcars were leased to the American occupying forces until 1960. As the vehicles aged, the inventory of the VT60.5 shrunk by the mid-1960s and the Rheine railway depot became the de facto discontinuation railway depot for the remaining railcars of the old design belonging to DB. With a fleet of six vehicles, the inventory was the highest here at the start of the 1970s. Four more vehicles were stationed in Nuremberg and two further vehicles were also in service; one in Heilbronn and one in Kassel. These 12 vehicles, which were issued with the EDP-compliant 660 designation, were all removed from regular service by 1972. Converted to radio measurement wagons, the former 660 506 and 660 531 remained in service until 1979. Only the VT 60 531 exists today. Only three railcars - the 137 348, 137 366 and the 137 387 - remained in the Soviet occupation zone following the war. They were utilised from the Aschersleben railway depot. However, all of the railcars were removed from service by 1969 as a result of the poor availa-



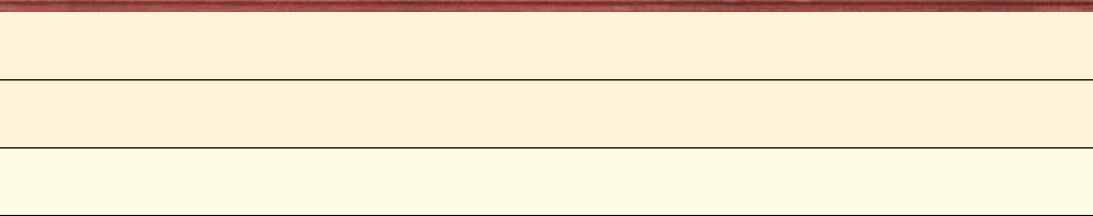

MULTI-PART INTERIOR FITTINGS

FREE STANDING STEPS



bility of replacement parts. Alongside the 40 railcars, the procurement plan also allowed for suitable VS145 control cars, particularly for the VT137 347 - 366 and 137 377 - 396. The wagons ordered in accordance with the CPost4ivS-36 sketch boasted 76 spaces in 3rd class, a control compartment at the front end and a post compartment at the rear end. As the control cars were largely delivered at a different time to the VT, the intended combinations did

not materialise from the start. In fact, the liberal applicability was utilised to deploy the VS with other VT designs. During the Federal Railway era, a total of 10 VS145 vehicles were documented for 1952 and were primarily used with the VT60.5. In contrast, the vehicles were also deployed with the VT36.5 or V36 in Bremen and Wuppertal. Now bearing the designation 945, the last VT60.5 was discontinued at Rheine in 1972 together with the last VS145.

Order no. <b>44740</b>	Analog BASIC+		Order no. <b>44742</b>	Digital EXTRA		
			Order no. <b>44743</b>	Digital EXTRA		



## Electric Railcar BR 426 BOB

Road no. 94 80 0426 040-2 /  
94 80 0426 540-1

The regional railcars in the 426 series are used throughout the DB AG network. The 426 railcar has two units and achieves a maximum speed of 160 km/h. The two final bogies are driven, and the central Jacobs-type bogie is not driven. The total installed power is 1,175 kW. When the railcar is braked, electrical energy can be fed into the mains and the released heat can be used for heating purposes.



Order no.  
**44640**



Order no.  
**44642**



Order no.  
**44643**

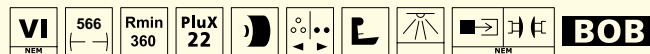

## Electric Railcar BR 425 „DB Regio NRW“ DB AG

Road no. 94 80 425 059-3



Order no.  
**44648**

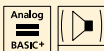

Order no.  
**44650**



Order no.  
**44651**



For use in regional traffic, DB AG procured numerous new vehicles that were primarily designed as railcars at the end of the 1990s. Consequently, 249 units of a four-part electric railcar which was given the BR 425 designation were also procured from the Siemens/ Adtranz/ Bombardier/ DWA consortium between 1999 and 2008. An identical two-part version for less-frequented routes was also created and given the BR 426 designation. The car bodies are manufactured from aluminum extruded profiles and the windows are bonded flush. The car bodies support each other via Jacobs bogies and the end bogies are respectively driven by two three phase engines. The wagon is fully accessible from the inside and has room for 206 seated and 228 standing passengers. The wagon also boasts 30 folding seats with a further 24 normal

seats in the first class cabin. The 425 was and continues to be utilized by DB Regio NRW; Baden-Württemberg; Südwest; Bayern; Südost; Nord; Schleswig-Holstein and Berlin; no private railway companies procured these railcars.

Tasks entrusted to this railcar included service in various suburban rail networks such as those in the Ludwigshafen–Mannheim–Heidelberg area of the Rhine-Neckar transport association as well as an RE service on long-distance routes. This includes routes such as Mannheim–Saarbrücken–Trier or Magdeburg–Stendal–Wittenberge–Salzwedel.

- Perfectly replicated three-dimensional front
- Extra mounted air conditioning installation and high voltage equipment
- Finely detailed pantograph
- Fine engravings
- In-plane assembled windows
- Functional and illuminated destination indicator

- Prepared for sound or with built-in sound
- With interior lighting
- Optimal power input
- NEM-standard short-coupling, for double taction
- Interior fittings
- Pick-up shoe switched by driving direction

- LED lighting
- Precise replica of the bogies, incl. consideration of all frame differences for the Electric Railcars BR 425 and BR 426
- Windscreen wipers individually mounted
- Destination indicator at the front sides behind the pane
- True-to-original rest position of the pantographs



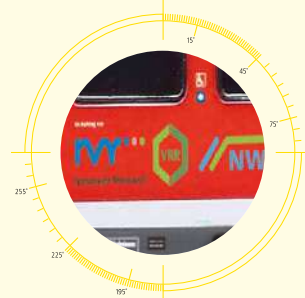

#### Functions of the Railcar BR 425

Functions of the Railcar BR 425	Analog BASIC+ =	Digital EXTRA =	Digital EXTRA ~
Driving function	+	+	+
Light change	+	+	+
Tail lights separately switchable		+	+
Driver cabin lighting	+	+	+
Passenger cabin lighting	+	+	+
Shunting lights		+	+
Long-distance headlights		+	+
Destination indicator	+	+	+
Light setting programmable for analogue operation		+	+
Digital interface	PluX22	PluX22	PluX22
Decoder		+	+
Sound		+	+
Additional information	<ul style="list-style-type: none"> <li>Subsequent conversion from analogue to digital version possible via PluX22 interface</li> </ul>	<ul style="list-style-type: none"> <li>Optimised light control for driving and shunting modes</li> <li>Latest sound technology and excellent sound quality</li> <li>Compatible with and programmable in all common digital systems (DCC, Motorola, SX1 and SX2)</li> <li>Improved motor and load control</li> </ul>	





# cityjet

## Electric Railcar Talent BR 4024 ÖBB Road no. 4024 127-4

The four-unit Talents in the 4024 series are in service in the Austrian capital city of Vienna's suburban rail network. They are 66.87 m long and their engines deliver 1,520 kW of power. The Talent family railcar's design also allowed for an electric drive unit. The Österreichische Bundesbahnen (ÖBB) is the first railway operating company to take advantage of this option.



Order no. **44266** Analog BASIC+  Order no. **44268** Digital EXTRA  

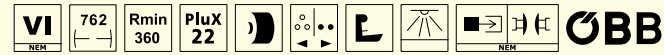

Order no. **44269** Digital EXTRA  



# S Bahn Steiermark

## Electric Railcar Talent BR 4024 ÖBB (Steiermark) Road no. 4024 039-1



Order no. **44270** Analog BASIC+  Order no. **44272** Digital EXTRA  

Order no. **44273** Digital EXTRA  

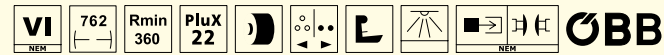

## Wien Handelskai

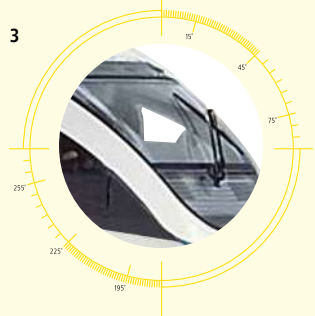
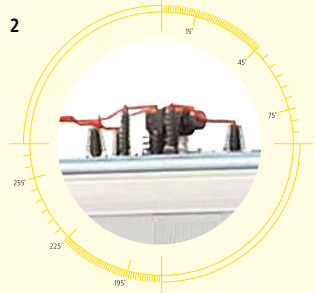
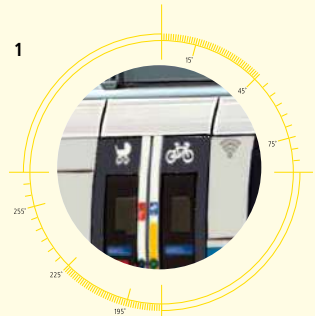

## Leoben Hbf



- 1\_Fine paintwork and printing
- 2\_Multipart roof-fittings
- 3\_Extra mounted windscreen wiper

(Photos show order no. 44270)

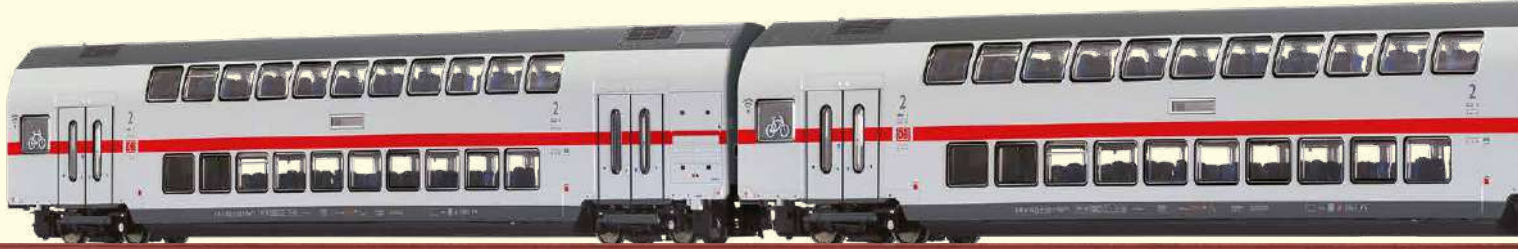

## NEW ORIGINALS ON THE HORIZON

TWINDEXX VARIO® IC2-DOUBLE-DECK COACHES DB AG

At the end of 2010, Bombardier Transportation obtained an order for 27 five-part Bombardier TWINDEXX Vario® double-decker push-pull trains belonging to the 2010 generation. The block trains with comfortable equipment for long-distance traffic consist of three 2<sup>nd</sup> class middle wagons, one 1<sup>st</sup> class middle wagon and

one 2<sup>nd</sup> class control car respectively. The TWINDEXX Vario® is a further development of the tried-and-trusted double-decker platform from Görlitz. Each train has 468 seats, 70 of which are in 1<sup>st</sup> class as well as 9 bicycle parking spaces. The top speed of the trains is 160 km/h.

TWINDEXX Vario® IC2 Middle Wagon DB AG, 2<sup>nd</sup> class  
Road no. 50 80 26-81 569-8

TWINDEXX Vario® IC2 Middle Wagon DB AG, 1<sup>st</sup> class  
Road no. 50 80 16-81 185-5



Order no.  
**44561**



Order no.  
**44565**

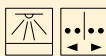

Order no.  
**44568**



Order no.  
**44562**



Order no.  
**44566**

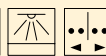

Order no.  
**44569**







**TWINDEXX Vario® IC2-Double-Deck Coaches DB AG, 3-unit, (1 Control Car, 2 Middle Waggon 2<sup>nd</sup> class)**  
 Road no. 50 80 86-81 881-4 / 50 80 26-81 567-2 / 50 80 26-81 568-0

Order no. <b>44560</b>		Order no. <b>44564</b>		
		Order no. <b>44567</b>		

**Product recommendation:** You can find the matching BR 147.5 electric locomotive on page 11 (Order no. 43834).

Technical Functions	Analog BASIC+ =	Digital EXTRA =	Digital EXTRA ~
Light change (Control Car)	+	+	+
Tail lights separately switchable	+ <sup>1)</sup>	+	+
Driver cabin lighting (Control Car)	+ <sup>1)</sup>	+	+
Passenger compartment lighting (lower and upper deck)	not retrofittable	+	+
Shunting lights	+ <sup>1)</sup>	+	+
Long-distance headlights	+ <sup>1)</sup>	+	+
Destination indicator	+ at the front side	+	+
All lights settings dimmable		+	+
Digital interface (Control Car)	PluX22		
Decoder (Control Car)		+	+
TrainBUS and Current Conducting Coupler		+	+
Sound		+ <sup>2)</sup>	+ <sup>2)</sup>
Additional information	<ul style="list-style-type: none"> <li>Necessary for AC operation: Replacement wheel set order no.: 2192, for the Control Car also necessary Decoder 99816 and AC pick-up 2225 (set no. 99817)</li> <li>Cannot be equipped with interior lighting</li> <li>Easy decoder installation</li> </ul> <p><sup>1)</sup> Function only available in digital mode</p> <p><sup>2)</sup> Sound functions only in connection with a locomotive, e. g. BRAWA BR 146.5 order no. 43976 available</p> <ul style="list-style-type: none"> <li>Interior lighting in each wagon can be individually controlled with ZugBUS (train BUS)</li> <li>Compatible with and programmable in all common digital systems (DCC, Motorola, SX1 and SX2)</li> </ul>		

DISCOVER ADDITIONAL FUNCTIONS OF THE IC2





# STREAMLINED MASTERPIECES WITH CHARACTERISTIC SIDE SKIRTS

EXPRESS TRAIN COACH GROUP 39 "SCHÜRZENWAGEN"



© RVM (WERKFOTO), SLG. EISENBAHNSTIFTUNG

With the introduction of the type 39 express coaches, the National Railway aimed to usher in the age of high-speed transport and increase the speed of its passenger trains. To achieve this goal, it was necessary to reduce the factors causing air turbulence in previous wagon types. As with the type 35 wagons, the type 39 relied even more heavily on welding technology. However, the designers' primary goal was to make the vehicles' exterior surface as smooth as possible. In particular, the areas under the frame and around the bogies had previously caused a lot of drag, so it made sense to clad these parts of the vehicle with side panels. Thus, the eponymous "Schürze" (side skirt) was conceived.

However, the design also included additional features that were considered advanced for the time. The entrance doors were installed flush to the exterior. An intricate folding mechanism ensured that the doors, despite having a low pivot point within the carriage, opened in conjunction with the side panels. The side window frames also sat flush with the exterior skin. To accommodate the necessary window well, the carriages were about 40 mm wider below the window sill.

In total, the National Railway planned to purchase over 1,000 carriages in various designs. Due to wartime constraints, however, only 543 production vehicles were delivered between 1939 and 1940 – 103 AB4ü-38s, 310 C4ü-38s, 65 ABC4ü-39s and 65 BC4ü-39s. Simultaneously, Mitropa initiated a revision of the WR4ü-35 design in collaboration with the wagon industry. Unlike the passenger carriages, this was not based on an entirely new design. Instead,

the externally positioned entrance doors were adapted and the frame skirting was added. The recessed windows were retained, as was the differing window height.

Due to the late delivery of these carriages, they were used rather infrequently until express train services were suspended due to the war. Many carriages were stored in supposedly secure railway stations to prevent their destruction. However, the fact that various wagons were written off as war losses indicates that this was not always successful.

Most of the vehicles that survived the war without damage remained in West Germany. The Federal Railway predominantly utilised the carriages for its nascent F-train network, alongside other carriages requisitioned by the occupying forces. At the time, these streamlined carriages were considered the most modern and comfortable passenger carriages on German tracks.

From the mid-1950s, increased deliveries of the new 26.4-metre wagons led to DB increasingly utilising these vehicles in its standard D trains. The streamlined "Schürzenwagen" would remain in DB's vehicle fleet until the mid-1970s, at which point the last units were retired and transferred to reserve fleets for military and troop transport. The wagons remaining in service with the National Railway (DR Ost) were transferred to its modernisation programmes in the early 1960s and converted into so-called "modernisation wagons". Some vehicles also remain in service with Austrian Federal Railways and SNCF.



- Wheelsets in toe bearing
- True to original axle box cover
- Brake shoes in wheel plane
- Extra mounted steps

- Individually mounted axle brake rod
- Multi-part brake system
- True-to-original interior fittings
- Wheel chocks attached

- Complete replica of the vehicle floor
- Interior lighting prepared or built-in
- NEM-standard short-coupling



**Passenger Coach AB4i DRG**  
Road no. 11 680 Bln



Order no. **51021** = Order no. **51027** =

Order no. **51033** ~

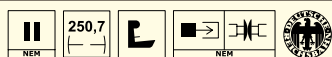

**Passenger Coach ABC4i DRG**  
Road no. 240 035 Stg

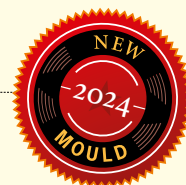

Order no. **51022** = Order no. **51028** =

Order no. **51034** ~

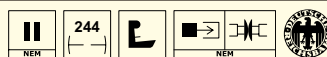

**Passenger Coach C4i DRG**  
Road no. 19 380 Reg



Order no. **51023** = Order no. **51029** =

Order no. **51035** ~

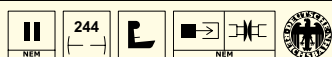

**Passenger Coach C4i DRG**  
Road no. 19 381 Reg



Order no. **51024** = Order no. **51030** =

Order no. **51036** ~

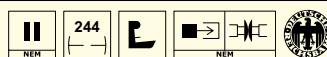

**Passenger Coach C4i DRG**  
Road no. 19 255 Stg



Order no. **51025** = Order no. **51031** =

Order no. **51037** ~

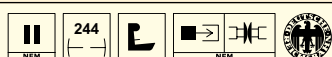

**Dining Car Hnbr MITROPA**  
Road no. 1206



Order no. **51026** = Order no. **51032** =

Order no. **51038** ~

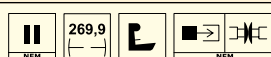

All pictures show illustrations.





Order no. **51039** =

Order no. **51047** =

Order no. **51055** ~

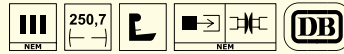

Passenger Coach A4üe DB  
Road no. 11 648 Ffm



Order no. **51040** =

Order no. **51048** =

Order no. **51056** ~

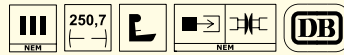

Passenger Coach A4üe DB  
Road no. 11 706 Ffm



Order no. **51041** =

Order no. **51049** =

Order no. **51057** ~

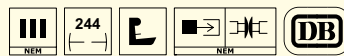

Passenger Coach AB4üe DB  
Road no. 14 640 Hmb



Order no. **51042** =

Order no. **51050** =

Order no. **51058** ~



Passenger Coach B4üe DB  
Road no. 17 469 Nür





Order no. **51043** =

Order no. **51051** =

Order no. **51059** ~

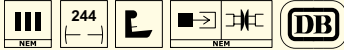

Passenger Coach B4üe DB  
Road no. 17 508 Nür



Order no. **51044** =

Order no. **51052** =

Order no. **51060** ~

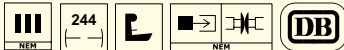

Passenger Coach B4üe DB  
Road no. 17 549 Nür



Order no. **51045** =

Order no. **51053** =

Order no. **51061** ~

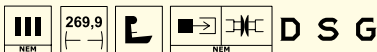

Dining Car WR4üge DSG  
Road no. 1169

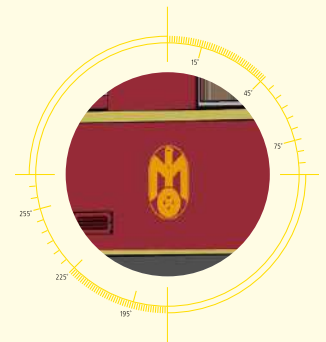

Order no. **51046** =

Order no. **51054** =

Order no. **51062** ~



Dining Car WRüge DSG  
Road no. 1201

All pictures show illustrations.





Order no. **51063** =

Order no. **51069** =

Order no. **51075** ~

Passenger Coach A4üe DR  
Road no. 243-012

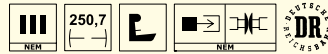

Order no. **51064** =

Order no. **51070** =

Order no. **51076** ~

Passenger Coach AB4üe DR  
Road no. 243-106

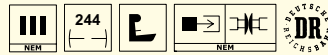

Order no. **51065** =

Order no. **51071** =

Order no. **51077** ~

Passenger Coach B4üe DR  
Road no. 243-209

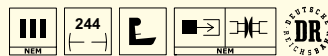



Order no. **51066** = Order no. **51072** =

Order no. **51078** ~

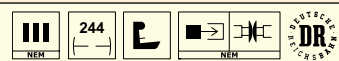

Passenger Coach B4üpe DR  
Road no. 243-202



Order no. **51067** = Order no. **51073** =

Order no. **51079** ~

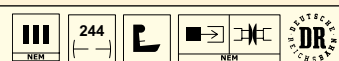

Passenger Coach B4üpe DR  
Road no. 243-216



Order no. **51068** = Order no. **51074** =

Order no. **51080** ~

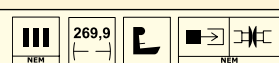

Dining car WR4ü-39 MITROPA  
Road no. 1165

All pictures show illustrations.



Passenger Coach A4üh ÖBB  
Road no. 11 330



Order no. <b>51102</b>	=				Order no. <b>51108</b>	=			
					Order no. <b>51114</b>	~			

**ÖBB**

Passenger Coach AB4üh ÖBB  
Road no. 12 350



Order no. <b>51103</b>	=				Order no. <b>51109</b>	=			
					Order no. <b>51115</b>	~			

**ÖBB**

Passenger Coach B4üh ÖBB  
Road no. 30 605



Order no. <b>51104</b>	=				Order no. <b>51110</b>	=			
					Order no. <b>51116</b>	~			

**ÖBB**

Passenger Coach B4üh ÖBB  
Road no. 30 593



Order no. <b>51105</b>	=				Order no. <b>51111</b>	=			
					Order no. <b>51117</b>	~			

**ÖBB**

Passenger Coach B4üh ÖBB  
Road no. 30 600



Order no. <b>51106</b>	=				Order no. <b>51112</b>	=			
					Order no. <b>51118</b>	~			

**ÖBB**





Passenger Coach A<sup>3</sup>B<sup>5</sup>myfi SNCF  
Road no. 1802

Passenger Coach B<sup>10</sup>myfi SNCF  
Road no. 13625



Order no. **51120** = Order no. **51123** =

Order no. **51126** ~

Order no. **51121** = Order no. **51124** =

Order no. **51127** ~



Passenger Coach B<sup>10</sup>myfi SNCF  
Road no. 13629



Order no. **51122** = Order no. **51125** =

Order no. **51128** ~



All pictures show illustrations.

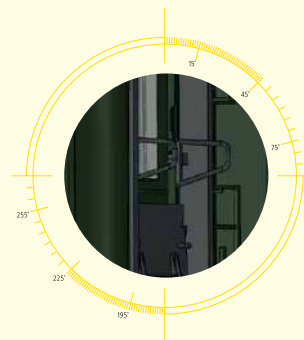
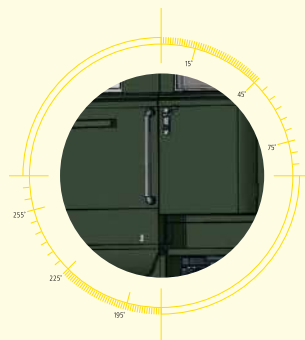



Order no. **51081** =

Order no. **51088** =

Order no. **51095** ~



Passenger Coach Aüe³¹⁰ DB  
Road no. 51 80 17-43 043-1



Order no. **51082** =

Order no. **51089** =

Order no. **51096** ~

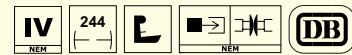

Passenger Coach ABüe³³⁴ DB  
Road no. 51 80 38-40 107-2



Order no. **51083** =

Order no. **51090** =

Order no. **51097** ~



Passenger Coach Büe³⁶⁶ DB  
Road no. 51 80 29-43 721-8



© K. GERKE, SLG, C. VON NEUMANN





Order no. **51084**

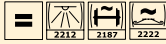

Order no. **51091**



Order no. **51098**

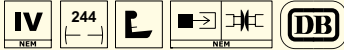

Passenger Coach Bue<sup>366</sup> DB  
Road no. 51 80 29-43 752-3



Order no. **51085**

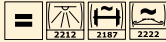

Order no. **51092**



Order no. **51099**



Passenger Coach Bue<sup>366</sup> DB  
Road no. 51 80 29-43 765-5



Order no. **51086**

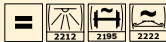

Order no. **51093**



Order no. **51100**

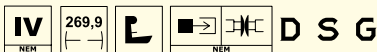

Dining Car WRüge<sup>152</sup> DSG  
Road no. 51 80 88-46 174-5



Order no. **51087**

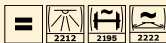

Order no. **51094**



Order no. **51101**

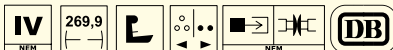
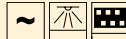

Dining Car WRüge<sup>152</sup> DB  
Road no. 51 80 88-40 187-3

All pictures show illustrations.



Passenger Coach Cid-21 DRG  
Road no. 80 013 Mainz



Order no.  
**45767**

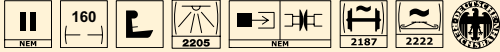

Passenger Coach CPostid DRG  
Road no. 90 974 Karlsruhe



Order no.  
**45768**

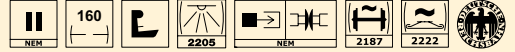

Passenger Coach Bid DB  
Road no. 80 981 Kassel



Order no.  
**45769**



Passenger Coach Bid DB  
Road no. 80 166 Kassel



Order no.  
**45770**

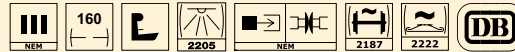

Passenger Coach Bid DR  
Road no. 340-417



Order no.  
**45771**

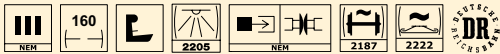

Passenger Coach Bid DR  
Road no. 340-331



Order no.  
**45772**

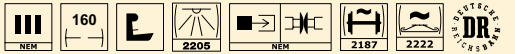

Passenger Coach B4yge DB  
Road no. EB 65 023 Stuttgart



Order no. **46100**        

Passenger Coach AByg 503 DB  
Road no. 50 80 38-11 388-4 Esn / Dortmund



Order no. **46101**        

Passenger Coach Byg 516 DB  
Road no. 50 80 29-12 941-0 Esn / Dortmund



Order no. **46102**        

Passenger Coach Byg 514 DB  
Road no. 50 80 29-11 534-4 Esn / Dortmund



Order no. **46103**        

Passenger Coach BDyG 532 DB  
Road no. 50 80 82-12 177-5 Esn / Dortmund



Order no. **46104**        



**Passenger Coach BCymb-51 DB**  
Road no. 30182 Nürnberg /  
Nürnberg Hbf



Order no. **58064**



Order no. **58106**

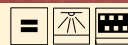

Order no. **58110**

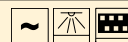

**Passenger Coach C4mgb-51 DB**  
Road no. 40583 Nürnberg /  
Nürnberg Hbf



Order no. **58065**

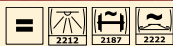

Order no. **58107**



Order no. **58111**

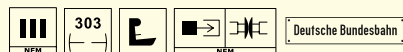

## PASSENGER COACHES YL

The 26.4 m express train wagons were introduced before the express coaches of the same length. Around 1950, DB, together with a number of wagon factories under the management of the Wegmann company, began development of new four-axle passenger carriages for district and long-haul transport at medium distances. After building three test coaches with a length of 26.4 m with central and end doors, the company finally decided on this type of construction. In late 1951 the first order for 500 of these carriages was placed with 15 coachbuilders. In the following years additional orders were placed for 245 units, the delivery of which would drag on until early 1955.

The two basic types were the mixed-class AB carriage and the single-class B carriage. On the basis of the latter type, various push-pull train control cars were developed to meet traction requirements for push-pull operations and, for traffic reasons, carriages with luggage compartments or dining areas were also designed.

The running gear (Minden/Deutz-type bogie) and the structural design were basically the same for all types. The undercarriage and body frame were a welded sectional steel construction. Special attention was paid to sound and heat insulation, the cost of which had to be kept within reasonable limits, in keeping with the planned use of the carriages in district traffic. The walls and undercarriage were lined with rock wool, the roof with a sprayed insulation consisting of asbestos flakes. Apart from two designs, the carriages were di-

vided into two passenger compartments of different lengths by the central doors, which were actually located slightly off-centre. The central doors featured two relatively narrow revolving doors and a central pillar, while the end doors with their wide revolving doors, whose centre of rotation was moved inwards, and the somewhat more favourable arrangement of the steps allowed convenient entry and exit. Multi-part folding doors formed the end of the front wall, which, when closed, protruded into the vestibule like a box to keep the "Bern rectangle" free.

The seating arrangement in the passenger compartments was 1 + 2 in the upper and 2 + 2 in the lower-class carriage. The toilets were located at the ends of the carriages and protruded into the large vestibules. The interior design of the carriages was relatively simple, but nevertheless dignified. In the first-class areas, the walls and the frames of the upholstered seats were covered with fine wood veneer; in second class, the wall surfaces were coated with plastic wallpaper. The upholstery in the first-class carriage corresponded to the standard design in use by Deutsche Bahn at the time. The second-class carriage was equipped with upholstered double seats covered with imitation leather. The luggage racks in both classes consisted of thin-walled, high-strength tubular steel and were coated with stove enamel in a nickel silver colour.

A high-pressure heating system was installed, which could be regulated in fine degrees by opening and closing heat-insulating flaps.





Order no. **58066**

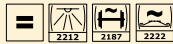

Order no. **58108**



Order no. **58112**



**Passenger Coach C4ymgb-51 DB**  
Road no. 40578 Nürnberg /  
Nürnberg Hbf



Order no. **58067**

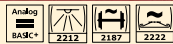

Order no. **58109**



Order no. **58113**

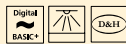

**Control Car CPw4ymgf-51 DB**  
Road no. 99121 Nürnberg /  
Nürnberg Hbf

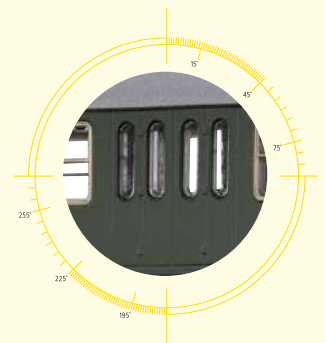
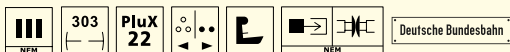

The main steam pipe under the carriage, a common feature in other models, was removed. In addition to the steam heating, a normal electric heater rated for 1,000 volts was installed, whose resistance heating elements were arranged under the seats so that the floor remained unobstructed.

Given the importance of push-pull operations within the framework of the structural transformation of the traction haulage service, as well as the need to unburden the over-utilised (terminus) railway stations, all express train wagons were designed for this purpose and prepared for subsequent installation of the necessary equipment, such as control lines and the main tank air line (8 atmospheres). 118 carriages received driver's cabs. Initially, however, only some of these carriages and the associated piped wagons were fitted with all equipment necessary for operation by remote control.

Located at one end of the carriage, the driver's cabs were completely identical in all three push-pull control car types; the operational requirement to be able to use these carriages freely like normal carriages resulted in a head section with foot bridge. The floor plans show the arrangement of the driver's cab and the conductor's compartment on both sides of the central passageway in the carriage's head section. Two hinged doors with window panes were arranged so that one of them formed the end exterior wall when used as a control car. When used in normal trains it served as the end of the driver's compartment. Analogously, the other door either connected the head section to the interior or served as the end of the driver's cab. This sensible arrangement of the doors allowed free movement from carriage to carriage if necessary.

- True-to-scale reproduction of the windows
- Wheel sets of type 094/096 with corrugated wheel discs on both sides
- True-to-epoch interior fittings
- Interior lighting prepared or built-in

- Elastic rubber bulge
- NEM-standard short coupling
- Version with riveted roofs and overlapping roof plates
- Alternator on bogie separately mounted

- Fine paintwork and printing
- Extra mounted steps
- Extra mounted handrails



**Passenger Coaches BPwif / Bib / ABib and Bib DB**  
 Road no. 84 856 Esn / 83 223 Esn / 36 120 Esn / 83 521 Esn



Order no. **46821** Analog BASIC+ 2212 2187 2222

Order no. **46824** Analog BASIC+ 2212

Order no. **46827** Digital BASIC+ 2212 D&H

III 640 NEM L NEM DB

**Model:** Command car with PluX22 interface and triple headlights; AC version: Command car with decoder

**Passenger Coach Bib DB**  
 Road no. 83 626 Esn

**Passenger Coach Bib DB**  
 Road no. 83 735 Esn



Order no. **46822** 2212 2187 2222

Order no. **46825** 2212

Order no. **46828** 2212

III 160 NEM L NEM DB

**Product recommendation:** Add-on car for our push-pull train set (Order no. 46821 ff)

Order no. **46823** 2212 2187 2222

Order no. **46826** 2212

Order no. **46829** 2212

III 160 NEM L NEM DB

**Product recommendation:** Add-on car for our push-pull train set (Order no. 46821 ff)

**Passenger Coach Bi DR**  
 Road no. 140 130

**Passenger Coach Bi DR**  
 Road no. 140 203



Order no. **45548**

III 148,9 NEM L 2212 NEM 2187 2222 DR

Order no. **45549**

III 148,9 NEM L 2212 NEM 2187 2222 DR

DEVIATING ROAD NO.





**Luggage Car Pwghs DB**  
Road no. 36 293



Order no. **46830** Order no. **46831**

Order no. **46832**

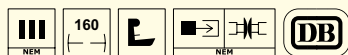

**Passenger Coach Ciph BBÖ**  
Road no. 37 328



Order no. **45535**

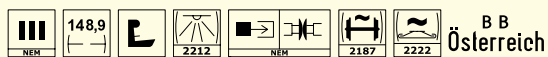

**Passenger Coach Cip BBÖ**  
Road no. 37 329



Order no. **45536**

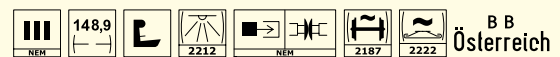







Order no. **46652**     

Order no. **46656**   

Passenger Coach ABnrz 403.4 DB AG  
Road no. 50 80 31-34 341-3

Order no. **46660**   



Order no. **46653**     

Order no. **46657**   

Passenger Coach Bnr 451.4 DB AG  
Road no. 50 80 22-35 369-4

Order no. **46661**   



Order no. **46654**     

Order no. **46658**   

Passenger Coach Bnrz 436.0 DB AG  
Road no. 50 80 22-34 231-7

Order no. **46662**   



Order no. **46655**     

Order no. **46659**  

Control Car Bnrzf 463.0 DB AG  
Road no. 50 80 82-34 096-1

Order no. **46663**   

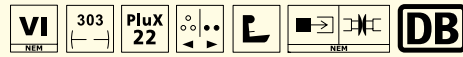



Order no. **46628**

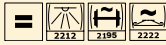

Order no. **46632**

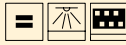

Order no. **46636**



**Passenger Coach ABnrz<sup>417.6</sup> TRI**  
Road no. 50 80 31-34 413-0

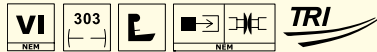

Order no. **46629**

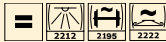

Order no. **46633**

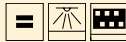

Order no. **46637**



**Passenger Coach Bnrz<sup>451.1</sup> TRI**  
Road no. 50 80 22-34 160-8

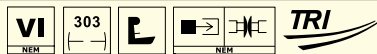

Order no. **46630**

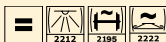

Order no. **46634**

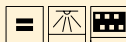

Order no. **46638**



**Passenger Coach Bnrz<sup>450.3</sup> TRI**  
Road no. 50 80 22-35 957-6



Order no. **46631**

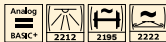

Order no. **46635**



Order no. **46639**



**Control Car Bnrzf<sup>463.0</sup> TRI**  
Road no. 50 80 82-34 241-3

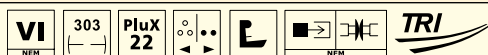

# GDR EXPRESS TRAIN CLASSIC

PASSENGER COACH BGHW "REKOWAGEN"

Like the DB, the DR also struggled after the Second World War with the enormous maintenance costs of ageing wooden type compartment coaches. It was therefore also decided at the Deutsche Reichsbahn to completely redesign the sub-frames to a uniform length. In 1963 the first coaches of this design were supplied by the repair shop in Halberstadt to the DR. This procedure was quickly given up due to the poor condition of the reused assemblies. It was decided to build the coaches completely with new components. The running gear used was the recently developed, „Görlitz V“ bogie without axle holders. The selected length of 18.7 m resulted from the structural conditions of the factory. Thus from 1963 to 1977, 3030 coaches of Class „Bghwe“ were produced, which was therefore to be found in nearly every passenger coach of

the DR in the 1970s and 1980s. Initially the coaches were used especially in special trains, due to their very modern comfort, and therefore also reached destinations in the Federal Republic. They were regularly seen in Nuremberg, Hamburg and the Ruhr area. When they appeared their livery was green with a continuous decorative stripe under the windows offset by a black sole bar band. Although the DR had planned to convert coaches, for example with new windows and new interior furnishings, they were removed from stock by 1995 after unification of the two German railways due to altered traffic conditions. Vehicles of this type are still used today by the DB AG and by many clubs and heritage railways.



Order no. **50809**

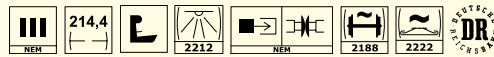

Passenger Coach B4mgl DR  
Road no. 260-286



Order no. **50810**

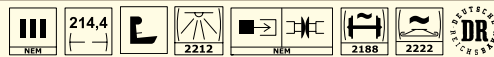

Passenger Coach B4mgl DR  
Road no. 260-293

DEVIATING ROAD NO.



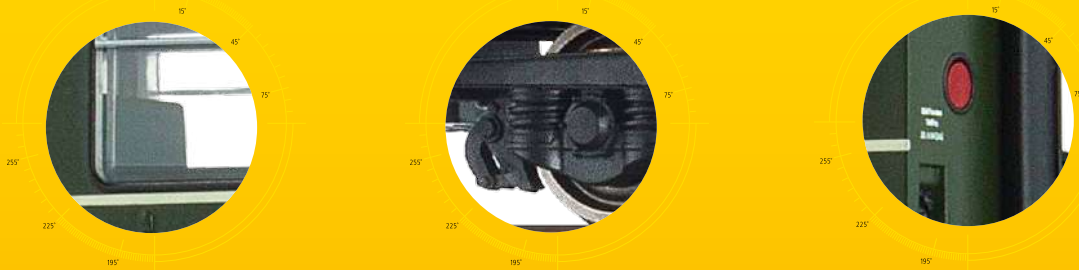

- Printed window frames
- Precise replica of the Görlitz V bogies
- Prepared for interior lighting

- Interior fittings in multicolour painting
- NEM-standard short coupling
- Alternator on bogie separately mounted

- In-plane assembled windows
- Fine paintwork and printing
- Passageway with separately mounted rubber beading

DEVIATING ROAD NO.



Order no. **50811**

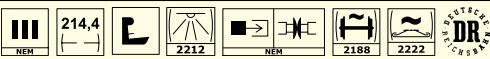

**Passenger Coach B4mgl DR**  
Road no. 260-298

DEVIATING ROAD NO.



Order no. **50812**

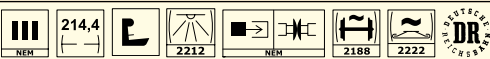

**Passenger Coach B4mgl DR**  
Road no. 260-300



Sleeperette A K.W.St.E.  
Road no. 162



Order no.  
**45619**

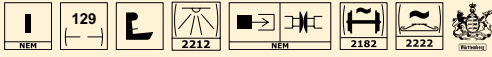

Passenger Coach Bi DRG  
Road no. 36 027



Order no.  
**45621**



Passenger Coach BC4 SBB  
Road no. 4951



Order no.  
**45713**

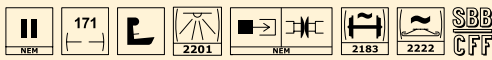

Passenger Coach C4 SBB  
Road no. 9301



Order no.  
**45714**

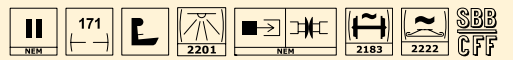

Luggage Car F4 SBB  
Road no. 18793



Order no.  
**45715**

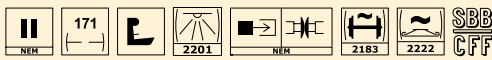

Passenger Coach C4 SBB  
Road no. 9410



Order no.  
**45716**



Passenger Coach SBB  
Road no. 95 358



Order no.  
**45712**

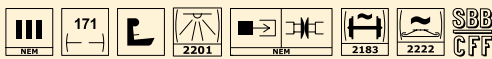



★

AUTOMATICALLY RECEIVE  
NEWS FROM BRAWA

Simply subscribe to the free BRAWA  
newsletter at [www.brawa.de](http://www.brawa.de) and you'll  
always know what's currently happening.





# MOST BEAUTIFULLY DESIGNED AUXILIARY LUGGAGE WAGONS

LUGGAGE CAR MDYG DB

After the war, there was a major lack of luggage wagons for high-speed long-distance trains. However, the young DB decided to use the available money to construct new passenger carriages and to solve the luggage wagon problem through conversions. In order to do so, it used approximately 600 substitute passenger carriages that remained in its inventory. Passengers could not be expected to travel in these wagons due to their interior fittings and their mediocre running properties. Two of these car bodies were connected, equipped with a strut bracing and placed on two American-design bogies. The approximately 290 luggage wagons that were produced in this manner from 1950 onwards were given the MPw4ie-54/55 and MPw4yg-57 designations. Although the first wagons were only equipped with the open entrance platforms from their donor carriages, they were quickly replaced with a "transfer tunnel" in order to offer a transfer to the next wagon whilst also being protected against the elements. This transfer was also then equipped with a rubber bulge in order to connect to modern wagons. DB arranged for numerous medical and auxiliary equipment cars to be built using the same construction principles. To begin with, the wagons were

first used in the premium high-speed train service. However, they were then moved to express goods and district services upon the emergence of new wagons. Some wagons were given additional equipment for the transport of freshly-hatched chicks and travelled in express trains between Italy and Germany. Numerous wagons that were given the designations MDyg-986 and -996 from 1966 onwards were further modernised and equipped with panel walls and new rubber-mounted windows. These wagons also remained in use in this design after 1989 and were also used in the DR (German Railway) area for the transport of express goods. The use of these wagons was halted suddenly in 1992 following a tragic train accident. A buffer fell from a track maintenance wagon causing 14 goods wagons to derail with which an approaching express train collided. The cause was material fatigue on the console upon which the buffers were fastened in order to create space for the access platform. Consequently, all wagons equipped with such consoles were removed from service and only those that had to be used were refurbished. This affected the auxiliary equipment cars built on the same principle but did not affect the MDyg.



Order no.  
**46273**

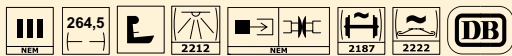

**Luggage Car MPw4ie DB**  
Road no. 113 845 Kassel



Order no.  
**46265**







**Luggage Car MDyg<sup>986</sup> DB**  
Road no. 50 80 92-11 897-7







Luggage Car Pg K.P.E.V.  
Road no. Breslau 3124



Order no. **48367**  97,8    





Luggage Car Pwg DB  
Road no. 126 576



Order no. **48369**  97,8    





Luggage Car Pwg DR  
Road no. 88-80-21



Order no. **48371**  97,8    



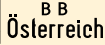

Luggage Car Pwg BBÖ  
Road no. 75 038



Order no. **48372**  97,8    





Luggage Car Pwg pr 14 DRG  
Road no. 131 628



Order no. **49429**  97,7    

Luggage Car Pwg DR  
Road no. 88-31-15



Order no. **49432**  97,7    

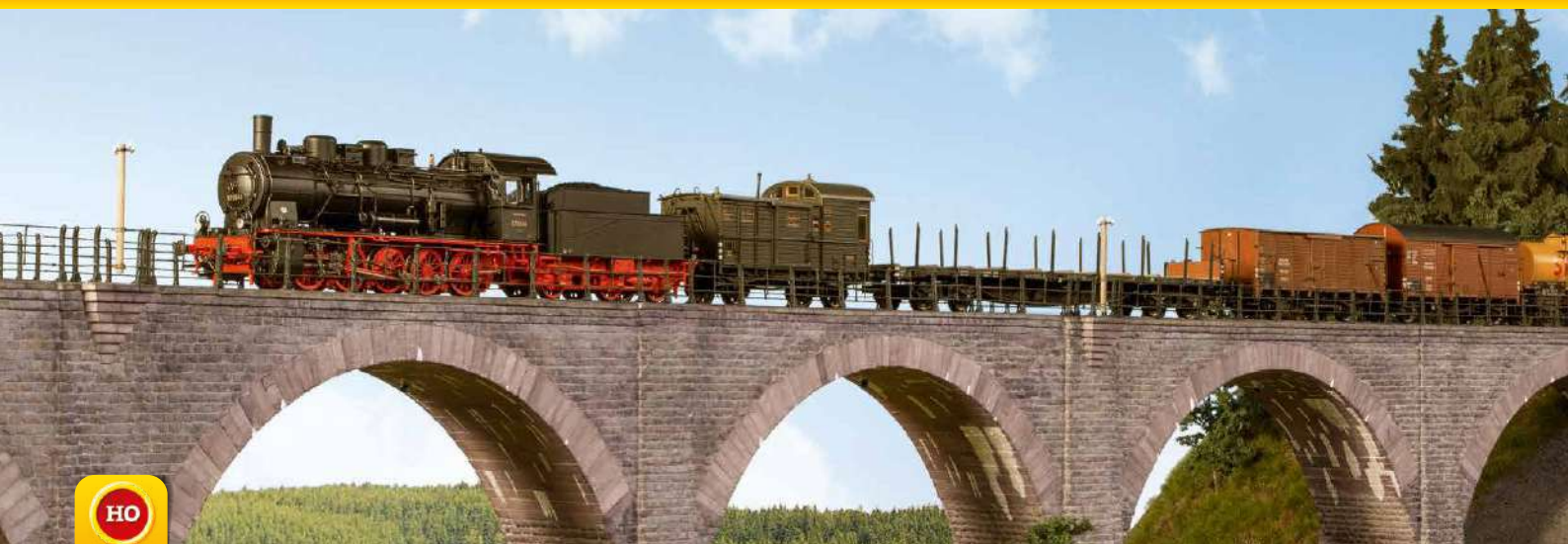



**Covered Peak Roof Cars F<sup>c</sup> FS, set of 2**  
Road no. 121 335 / 1152 507



Order no.  
**48572**



**FS**  
Italia

**Covered Peak Roof Cars F FS, set of 2**  
Road no. 1139 380 / 1135 341



Order no.  
**48573**



**FS**  
Italia

**Covered Freight Car G K.Bay.Sts.B.**  
Road no. Regensburg 32 112

DEVIATING ROAD NO.



Order no.  
**48045**



**Flat Car X K.Bay.Sts.B.**  
Road no. Augsburg 81 613

DEVIATING ROAD NO.



Order no.  
**48050**



**Covered Freight Car Gb "OEVA" k.k.St.B.**  
Road no. 215009 [P]



Order no.  
**50976**



**K.K.**  
**St.B.**

\*

**PERFECTLY EQUIPPED**

You can now find lamps, cable railways, a variety of equipment details and a wide range of electrical accessories for HO and N at [www.brawa.de](http://www.brawa.de).

HO







N











**Covered Freight Car G "AEG" DRG**  
Road no. Berlin 531 611 [P]



Order no. **50791**      





**Covered Freight Car L "Trebonske Pivovary" CSD**  
Road no. 512508 [P]



Order no. **50993**      

**Covered Freight Car G "Gräf & Stift" BBÖ**  
Road no. 125 662



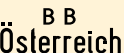





Order no. **50974**      









**Beer Car H1f "Kronenbourg" SNCF**  
Road no. 505028 [P]



Order no. **50994**      







**Covered Freight Car "SPA Monopole" SNCB**  
Road no. 3315208



Order no. **50995**      

**Covered Freight Car Gklm<sup>191</sup> DB, set of 2**  
Road no. 21 80 112 8 919-4 / 21 80 112 8 554-9



Order no. **50930**      





# FOR HAZARDOUS FREIGHT TRANSPORT. DANGEROUSLY TRUE-TO-ORIGINAL.

GAS TANK CAR ZZD [P]



ILLUSTRATION

## Gas Tank Car 6-axle ZZd "Ammoniakwerk Merseburg" DRG Road no. Halle 562 802 [P]



In 1941, the Heidelberg company Waggonfabrik Fuchs delivered the first 6-axle gas tank wagons to the National Railway. With a length over buffers of 14.6 metres and a tank volume of 42.5 m<sup>3</sup>, these vehicles were a good deal larger than the acid tank wagons, which were based on the same design. The wagons utilised for gas transport were essential for conveying butane and propane. The National Railway sent these wagons to customers in West Germany, including the private wagon leasing company VTG. In the East, the wagons were utilised directly by the National

Railway. To prevent excessive heating of the gas loaded in the tanks due to solar radiation, and the resulting expansion and pressure build-up inside the tank, some of the wagons were fitted with a sun shield. On the wagons operated by the National Railway (East), the conversion of the boiler access was documented. This could no longer be done from the sides, but only from the hand-brake platform.

Order no.  
**50086**

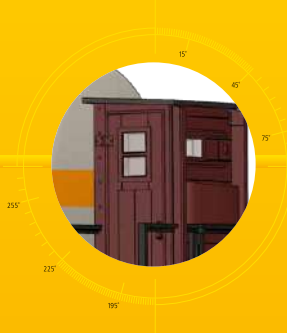
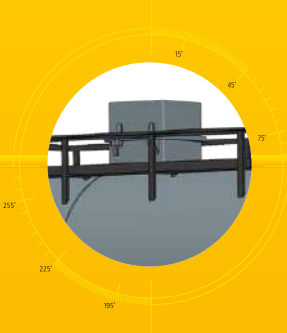

- Variants with and without sunroof
- Bogie with three-point support
- Precise paintwork and printing

- Individually mounted brake systems
- Finely engraved bogies
- Brake blocks in wheel plane

- Free standing handle bars
- Individually mounted axle brake rod



Gas Tank Car 6-axle ZZd "Wifo Berlin" DRG  
Road no. Hannover 906 537 [P]



ILLUSTRATION

Order no. **50087** III 167,4 NEM NEM 2187

Gas Tank Car 6-axle ZZd "VTG" DB  
Road no. 598 901 [P]



ILLUSTRATION

Order no. **50091** III 167,4 NEM NEM 2187 DB

Gas Tank Car 6-axle ZZd "VTG" DB  
Road no. 598 902 [P]



ILLUSTRATION

Order no. **50092** III 167,4 NEM NEM 2187 DB

Gas Tank Car 6-axle ZZd "VEB" Farbenfabrik Wolfen" DR  
Road no. 54-25-11 [P]



ILLUSTRATION

Order no. **50090** III 167,4 NEM NEM 2187 DR

Gas Tank Car 6-axle ZZdw "VEB Leuna-Werke" DR  
Road no. 21 50 076 9010-4 [P]



ILLUSTRATION

Order no. **50093** IV 167,4 NEM NEM 2187 DR

Gas Tank Car 6-axle ZZd "VTG" DB  
Road no. 21 80 075 0 050-5 [P]



ILLUSTRATION

Order no. **50088** IV 167,4 NEM NEM 2187 DB

Gas Tank Car Z 6-axle ZZd "VTG" DB  
Road no. 21 80 075 0 051-3 [P]



ILLUSTRATION







Order no. **50089** IV 167,4 NEM NEM 2187 DB



Tank Car 2-axle Z [P] "B.V. ARAL" DRG  
Road no. Essen 503 684 [P]

ILLUSTRATION









Order no. **50847**      

Tank Car 2-axle Z [P] "HOBUM" DB  
Road no. 579 592 [P]

ILLUSTRATION









Order no. **50849**      

Tank Car 2-axle Z [P] "BP" DB  
Road no. 581 642 [P]

ILLUSTRATION









Order no. **50851**      



Open Freight Car Ommstu "Rekord Briketts" DR  
Road no. 21 50 550 1143-5







DEVIATING ROAD NO.



Order no. **49552**      

Acid Carrying Car Z [P] "BASF" DRG  
Road no. Mainz 514 666 [P]









Order no. **49326**      

Open Freight Car E<sup>037</sup> SBB, with "turnip", weathered, set of 2  
Road no. 20 85 504 1322-3 / 20 85 508 8 019

LIMITED  
PATINIERT  
WEATHERED  
EDITION



Order no. **48640**      



Covered Freight Car Gms "Manner" ÖBB  
Road no. 140 674



Order no. **50903** III 104,6 NEM NEM 2187 ÖBB

Covered Freight Car Grhs DRG  
Road no. Opp 26 843



Order no. **50743** II 112,6 NEM NEM 2187 DRG

Covered Freight Car Kf SNCF  
Road no. 438736



Order no. **50750** III 112,6 NEM NEM 2187 SNCF

Covered Freight Car Gms30 DB  
Road no. 235 256



Order no. **50746** IV 112,6 NEM NEM 2187 DB

Covered Freight Car (Mosw) Mso DR  
Road no. 27 50 222 5114-2



Order no. **50749** IV 112,6 NEM NEM 2187 DR



Flat Car Xr35 DB, with gravel freight  
Road no. 460 854



Order no. **49358** III 104,6 NEM NEM 2187 DB

Flat Car Xr35 DB, with gravel freight  
Road no. 462 040



Order no. **49359** III 104,6 NEM NEM 2187 DB

Tank Car 2-axle Z [P] DRG  
Road no. Mainz 523 219 [P]



Order no. **50751** II 101 NEM NEM 2187 DRG

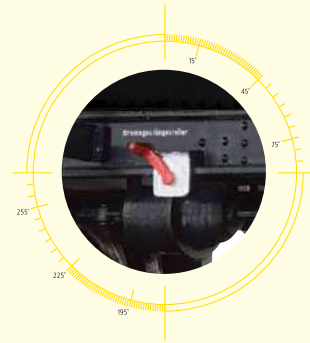

Tank Car 2-axle Z [P] "Persil" DB  
Road no. 544 190 [P]



Order no. **50754** III 101 NEM NEM 2187 DB

Tank Car 2-axle R CSD  
Road no. 8-71915 [P]



Order no. **50752** III 101 NEM NEM 2187 ČSD

Covered Freight Car Gos<sup>245</sup> DB  
Road no. 21 80 140 4 800-1



Order no. **47299** IV 143,7 NEM NEM 2187 DB

Covered Freight Car Gos<sup>1404</sup> DR  
Road no. 21 50 140 4457-6



Order no. **50909** IV 143,7 NEM NEM 2187 DR





Covered Freight Car Glm201 DB  
Road no. 248 910



Order no. **50722** III 115 NEM NEM 2187 DB

Covered Freight Car Gmhs DR  
Road no. 21 50 134 6321-5



Order no. **50726** IV 115 NEM NEM 2187 DR

Refrigerator Car Tnfhs38 "Transthermos" DB  
Road no. 568 010 [P]



Order no. **47640** III 139,1 NEM NEM 2187 DB

Refrigerator Car Tnfhs38 "Gaffel Kölsch" DB  
Road no. 536 050 [P]



Order no. **47642** III 139,1 NEM NEM 2187 DB

Refrigerator Car Tnfhs38 "Manner" ÖBB  
Road no. 21 81 807 2 023-7



Order no. **47648** IV 139,1 NEM NEM 2188 S

Covered Freight Car Glr22 "Kuba Imperial" DB  
Road no. 566 420 [P]



Order no. **50934** III 139,1 NEM NEM 2188 DB

Covered Freight Car IJ SNCF  
Road no. 600136



Order no. **50495** III 139,1 NEM NEM 2188 SNCF

Covered Freight Car Kuw CFL  
Road no. 23334



Order no. **50498** III 139,1 NEM NEM 2188 CFL





## MAXIMUM SAFETY FOR SENSITIVE CARGO

COVERING HOOD CAR SHIMMNS 708

Due to the rolling process during their production, sheet steel coils are susceptible to moisture. In the 1970s, seeking to protect such coils from corrosion during transport to processing industries, the rail vehicle industry developed a special type of flatcar with three nested sliding hoods – the Shis 708, which was also known as the Shimmns 708 from 1987 onwards.

To allow easy loading of the coils, the hoods can be opened as required, exposing the five loading troughs embedded in the vehicle frame. The Federal Railway placed orders for over 2,500 units of Shis/Shimmns

708 in two major batches. The actual number of vehicles of this design is significantly higher due to additional orders from other state railways and leasing companies.

As the hoods became increasingly maintenance-intensive with age, DB AG replaced them with sliding tarpaulins on 1,000 carriages and reclassified these vehicles as the Shimmns-ttu 772 from 2002 onwards. However, private operators continue to utilise some vehicles in their original condition.



© S. CARSTENS



- Sliding hoods not movable
- Lots of design differences
- Variants with parking and handbrake
- Lots of extra details
- Three-point bearing for safe operation
- Different bogies of several types
- Variant-appropriate arrangement of the Address boards



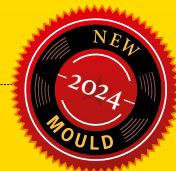

ILLUSTRATION

Order no. **51001**

Covering Hood Car Shis<sup>708</sup> DB  
Road no. 21 80 141 3 507-1



© F. WESTERMANN & S. CARSTENS

Order no. **50997**

Covering Hood Car Shimmns<sup>708</sup> DB  
Road no. 60 80 092 3 742-1



© S. CARSTENS

Order no. **50998**

Covering Hood Car Shimmns<sup>708</sup> DR  
Road no. 21 5 0 140 4457-6

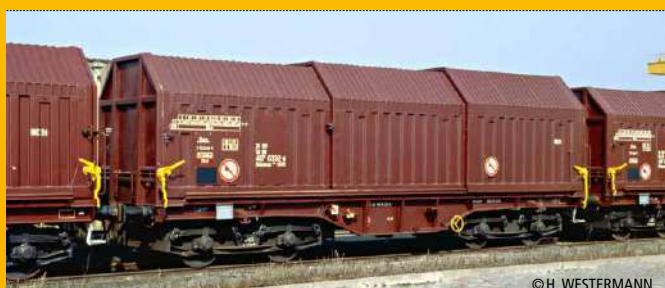

© H. WESTERMANN

Order no. **50999**

Covering Hood Car Shimmns-t<sup>708</sup> DB  
Road no. 31 80 437 3 137-7



© S. CARSTENS

Order no. **51000**



Covering Hood Car Shimmns<sup>2</sup> DB  
Road no. 31 80 467 1 111-1



Order no. **51005**

Covering Hood Car Shimmns-u<sup>708</sup> DB AG  
Road no. 31 80 477 7 167-6



Order no. **51004**

Covering Hood Car Shimmns-u 708 DB AG  
Road no. 31 80 467 1 111-1



Order no. **51002**

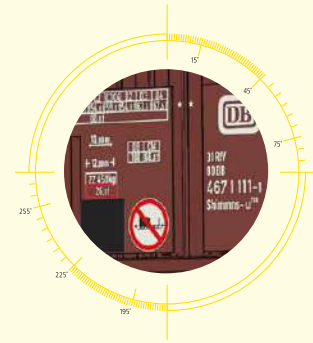

Covering Hood Car Shimmns<sup>730</sup> DB AG  
Road no. 31 80 467 1 037-8



Order no. **51007**

Covering Hood Car Shimmns-u<sup>708</sup> DB AG  
Road no. 34 80 477 7 001-4



Order no. **51008**

Covering Hood Car Shimmns-u<sup>708</sup> DB AG  
Road no. 31 80 467 1 279-6



Order no. **51009**

Covering Hood Car Shimmns<sup>2</sup> VTG  
Road no. 34 80 477 7 004-8









Order no. **51020**



Covering Hood Car Shis Type 3614B0 SNCB  
Road no. 31 81 466 8 170-1









© F. WILLKE, SLG. S. CARSTENS

Order no. **51016**      

Covering Hood Car Shimms<sup>385</sup> NS  
Road no. 31 88 437 3137-9



© DR. RUDOVON COSEL, SLG. S. CARSTENS







Order no. **51019**      



Covering Hood Car Shimms FS  
Road no. 35 83 466 9 945-3



ILLUSTRATION 

Order no. **51011**      

Covering Hood Car Shimms ÖBB, Rail Cargo Austria  
Road no. 31 80 4671 273-9









© B. WIESMÜLLER

Order no. **51012**      

Covering Hood Car Shimms SBB  
Road no. 31 81 466 9 011-6



© M. MAISS

Order no. **51015**      



Covered Freight Car Glimms "IMI" DR  
Road no. 21 50 150 0123-7



Order no. **49927** IV NEM 165,7 NEM 2187 DR DEUTSCHE SCHENKE

Covered Freight Car Glimms "ATA" DR  
Road no. 21 50 150 3487-3



Order no. **49928** IV NEM 165,7 NEM 2187 DR DEUTSCHE SCHENKE

Covered Freight Car Gbs "Fortschritt" DR  
Road no. 01 50 150 5146-7



Order no. **49930** IV NEM 165,7 NEM 2187 DR DEUTSCHE SCHENKE

Covered Freight Car Gbs<sup>[1500]</sup> "Konsum" DR  
Road no. 21 50 150 2549-2



Order no. **49931** IV NEM 165,7 NEM 2187 DR DEUTSCHE SCHENKE

Tank Car 2-axle Zw DR  
Road no. 21 50 700 1011-5 [P]

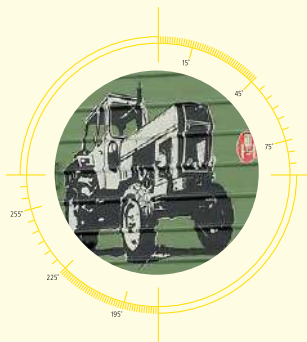

Order no. **50050** IV NEM 101 NEM 2188 DR DEUTSCHE SCHENKE

Covered Freight Car Gags-v "Fortschritt" DR  
Road no. 11 50 199 0444-6



Order no. **50410** IV NEM 189,6 NEM 2181 DR DEUTSCHE SCHENKE

Covered Freight Car Gags-v "Konsum" DR  
Road no. 11 50 199 2511-0



Order no. **50412** IV NEM 189,6 NEM 2181 DR DEUTSCHE SCHENKE



Covered Freight Car Gmms40 "Kali" DB  
Road no. 281 364



Order no. **50153** III 121,6 NEM NEM 2187 DB

Covered Freight Car Grs-60 Gmms DB  
Road no. 156 495



Order no. **50155** III 127,3 NEM NEM 2187 DB

Covered Freight Car Gs<sup>210</sup> DB  
Road no. 01 80 120 5 989-7



Order no. **50154** IV 121,6 NEM NEM 2187 DB

Covered Freight Car Gs<sup>1200</sup> DR  
Road no. 21 50 120 0012-5



Order no. **50146** IV 121,6 NEM NEM 2187 DR

Tank Car 4-axle ZZ [P] "Hugo Stinnes" DRG  
Road no. Altona 504 331 [P]



Order no. **48513** II 120,5 NEM NEM 2180.1 DR

Tank Car 4-axle ZZ [P] "Aral" DB  
Road no. 503 754 [P]



Order no. **48511** III 120,5 NEM NEM 2180.1 DB

Tank Car 4-axle ZZ [P] "Leuna" DR  
Road no. 51-72-33 [P]



Order no. **48518** III 120,5 NEM NEM 2180.1 DR

Tank Car 4-axle ZZ [P] "VTG" DB  
Road no. 20 80 005 1 041-7 [P]



Order no. **48516** IV 120,5 NEM NEM 2180.1 DB





# STANDARDIZATION IN EUROPEAN FREIGHT CAR TRAFFIC

OPEN FREIGHT CAR UIC-TYP II (OMM54 AND 55)



ILLUSTRATION

## Open Freight Car Omm55 DB Road no. 882 809



To promote the renewal of rolling stock and the standardisation of goods wagons among European state railways, the UIC (Union Internationale de Chemins de Fer) designed two variants of an open goods wagon at the beginning of the 1950s: the UIC Type I and UIC Type II. The UIC Type II closely adhered to the dimensions of 10.0 metres in length with a 5.4-metre wheelbase, drawing strong inspiration from pre-war German designs. The entire frame and wagon body were constructed using welded techniques. Upon completing the detailed design, the Federal Railway began upgrading its O-rolling stock at the Kaiserslautern workshop, using the UIC Type II as a basis. From 1954, 10,589 wagons of the Omm 54 types were produced in Kaiserslautern in just two years. Although officially considered conversions based on usable parts from older wagons, these wagons were largely built from new materials. An exception was the

brake components, for which Kkg brakes from donor wagons were utilised. In the subsequent construction batches – designated as Omm 55 – these brakes were also dispensed with and new KE brakes were installed, resulting in the procurement of over 17,300 units from 1955 onwards. Through numerous detailed improvements during production as well as later design changes, the vehicles were maintained throughout their lifecycle and were not completely retired until 1994. In addition to the Federal Railway, other state railways also procured wagons based on the UIC Type II specifications for their fleets. These were deployed by the DR Ost (East German Deutsche Reichsbahn), SNCF, SNCB, FS, MAV, ÖBB (Austrian Federal Railways), SBB, CSD, DSB and others, each featuring country-specific details or components.

Order no. **50058**









- Lots of design differences
- Variants with handbrake
- Lots of extra details
- Three-point bearing for safe operation
- Achshalter aus Metall
- Side doors with inside contours
- Wheels profiled on both sides
- Car floor of metal
- Different versions of the brake systems











Open Freight Car Omm55 DB  
Road no. 889 303



Order no. **50057**      

Open Freight Car Omm53 DB  
Road no. 878 841









Order no. **50056**      









Open Freight Car Omm55 DB  
Road no. 762 570



Order no. **50059**      







Open Freight Car Tow SNCF  
Road no. 699754

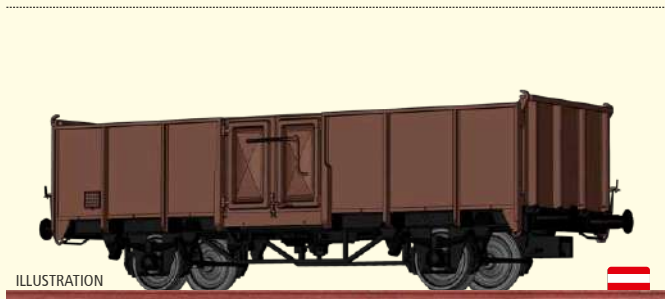

Order no. **50066**      







Open Freight Car Omm ÖBB  
Road no. 780 560



Order no. **50073**      







Open Freight Car L FS  
Road no. 4461 317



Order no. **50069**      







Open Freight Car 11 SNCB  
Road no. 2289004



Order no. **50071**      

Open Freight Car E DSB  
Road no. 53 493







Order no. **50076**      



**Open Freight Car Wddo P.K.P.**  
Road no. 483 303









© S. CARSTENS

Order no. **50079**     

**Open Freight Car ES<sup>050</sup> DB**  
Road no. 01 80 554 7 353-4









© S. CARSTENS

Order no. **50060**      

**Open Freight Car .E<sup>039</sup> DB**  
Road no. 01 80 507 5 744-4









© F. WILLKE, SLG. S. CARSTENS

Order no. **50061**      

**Open Freight Car .E<sup>039</sup> DB**  
Road no. 01 80 505 9 583-6







© F. WILLKE, SLG. S. CARSTENS

Order no. **50062**      

**Open Freight Car .E SNCF**  
Road no. 01 87 505 0 224-9









© F. WILLKE, SLG. S. CARSTENS

Order no. **50067**      

**Open Freight Car .E ÖBB**  
Road no. 01 81 502 4 145-5









© F. WILLKE, SLG. S. CARSTENS

Order no. **50074**      

**Open Freight Car .E FS**  
Road no. 01 83 5000 051-1



© F. WILLKE, SLG. S. CARSTENS

Order no. **50070**      

**Open Freight Car .E SNCB**  
Road no. 01 88 501 8 610-2

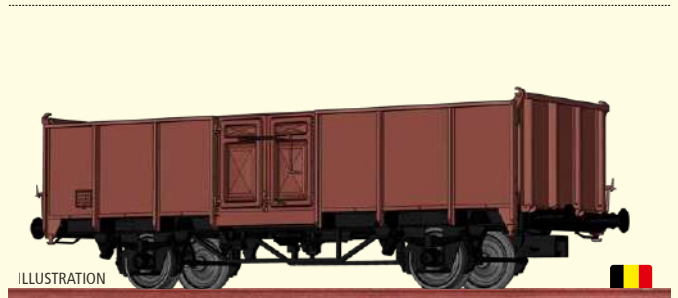





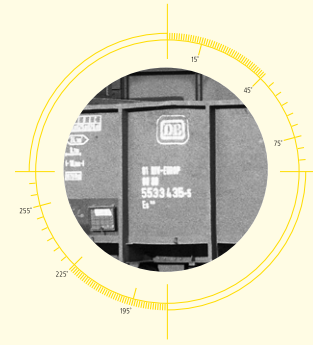

ILLUSTRATION  
Order no. **50072**      





Open Freight Car Es<sup>045</sup> DB  
Road no. 01 80 553 3 435-5



Order no. **50063**

Open Freight Car Es<sup>045</sup> DB  
Road no. 01 80 553 2 877-9



Order no. **50064**

Open Freight Car E<sup>040</sup> DB  
Road no. 01 80 507 4 848-4



Order no. **50065**

Open Freight Car Vte CSD  
Road no. Vte 21 54 555 0926-9



Order no. **50077**

Open Freight Car Es ÖBB  
Road no. 01 81 552 4 009-8

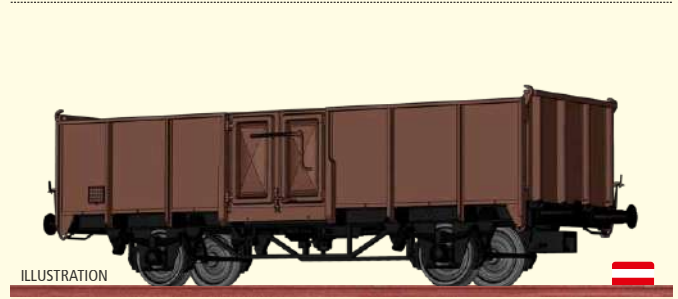

ILLUSTRATION Order no. **50075**

Open Freight Car SNCF  
Road no. 01 87 505 0 815-4

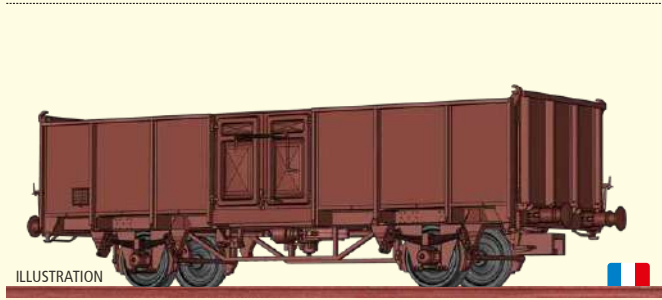
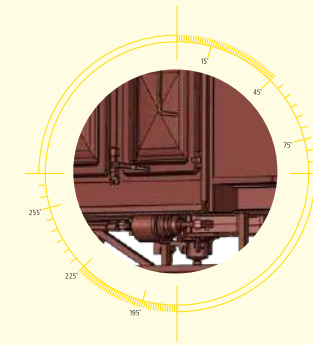

ILLUSTRATION Order no. **50068**



Container Car BTs30 "von Haus zu Haus" DB  
Road no. 010 373



Order no. **50910** III 115 NEM DB 2188

Container Car BTs30 "Südmilch" DB  
Road no. 010 281



Order no. **50917** III 115 NEM DB 2188

Container Car Lbs<sup>577</sup> "Südzucker" DB  
Road no. 20 80 411 0 096-6



Order no. **50922** IV 115 NEM DB 2188

Container Car Lbs<sup>577</sup> "Texaco" DB  
Road no. 20 80 411 0 102-2



Order no. **50928** IV 115 NEM DB 2188

Container Car BTs30 CSD  
Road no. 44 45 415 3010-9



Order no. **50925** IV 115 NEM ČSD 2188

Container Car KKds55 DB  
Road no. 358 022



Order no. **50315** III 162 NEM DB 2187

Container Car Sffggmrss<sup>36</sup> "MAERSK / Hapag-Lloyd" AAE  
Road no. 33 68 4909 549-0



Order no. **48109** VI 418,8 NEM AAE 2197



Tank Car Zas-w<sup>[7850]</sup> DR, set of 3

Road no. 31 50 727 0136-2 / 31 50 727 0084-4 / 31 50 727 0003-4



Order no.  
**50805**

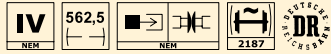

Tank Car Zas "Wasserwagen" Wiebe

Road no. 33 80 7856 316-4



Order no.  
**50807**



Tank Car Uia "DHL" GATX

Road no. 33 80 795 6 482-3 [P]



Order no.  
**50808**



Tank Car Zas SBB

Road no. 98 85 93-90 008-3



Order no.  
**50806**



Heavy Duty Freight Car Samms-u<sup>453</sup> DB

Road no. 31 80 486 7 592-6



Order no.  
**47583**

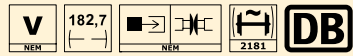

Container Car Sffggmrss<sup>36</sup> "APL / HANJIN" AAE

Road no. 33 68 4909 157-2



Order no.  
**48110**





## SMALL GAUGE WITH BIG DETAILS

TWINDEXX VARIO® DOUBLE-DECK TRAIN NAH.SH



### TWINDEXX VARIO® Double-Deck Train NAH.SH, 3-unit

Road no. 91 80 0 445 026-1 / 50 80 26-81 388-3 / 91 80 0 445 026-1

For many years now, double-decker trains have successfully formed the backbone of regional traffic. Double-decker trains are the ideal solution, especially on routes with low platform lengths and a high volume of passengers. The tried-and-tested single-wagon concept of the TWINDEXX Vario® double-decker fleet was supplemented with an electrical railcar. The four-part railcars from the "Do 2010" generation consist of 2 railcars and 2 middle wagons respectively. With the driven TWINDEXX Vario® railcar, it is now possible to utilise the trains as pure double-decker multiple unit trains. As a result, it is also possible to use this vehicle as an electric multiple unit train alongside the classic push-pull operation with an electric or diesel locomotive. This railcar can be combined with middle wagons and control cars depending upon the application and desired capacity. The

central buffer coupling enables operation with double traction and, as a result, the implementation of a wing-train concept. The trains with a combined upper and lower entrance are comfortably equipped with generous seat spacing and plenty of storage space. Furthermore, the double-decker individual wagons permit the extension and shortening of the block train and, consequently, an adjustment to fluctuating demand or future development. As a result, they can be utilised for the most diverse of operational applications in both regional and long-distance traffic.



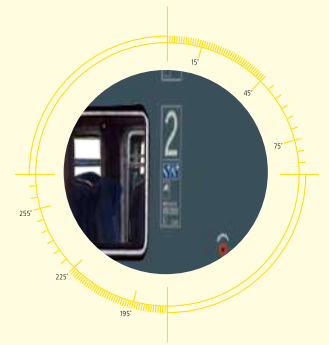

**TWINDEXX VARIO® Double-Deck  
Middle Car DBpza<sup>783.0</sup> NAH.SH**  
Road no. 50 80 26-81 388-3

Order no.  
**64549**

Order no.  
**64552**

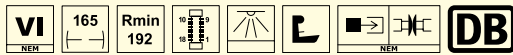

ILLUMINATED DESTINATION INDICATOR,  
SWITCHABLE (DIGITAL VERSION)

LONG-DISTANCE HEADLIGHTS  
(DIGITAL VERSION)



Order no.  
**64548**

Order no.  
**64551**



- True to original length over buffer
- Impact resistant body and chassis
- Metal bottom plate
- Printed window frames

- Lighting with warm white LED
- Individually mounted windscreen wiper
- True to original front
- Metal axle bearing

- Long-distance headlights (Digital version)
- Drivers cabin lighting (Digital version)
- Illuminated destination indicator, switchable (Digital version)
- Passenger compartment lighting



**Diesel Locomotive BR 132 DR**  
Road no. 132 339-3

Since 1973 the locomotives of Class 132 have provided good service in heavy duty freight and passenger transport. Due to the delivery of large numbers of the 120 kph locomotives equipped with electric train heating, the replacement of the last steam locomotives was also initiated at the Deutsche Reichsbahn.



PICTURE SHOWS HO-MODEL

Order no. **61046**      Order no. **61047** 

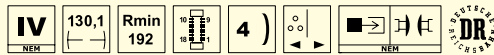

**Diesel Locomotive BR 132 DB AG**  
Road no. 132 618-0

As a subsidiary of DB AG, DB Bahnbau Gruppe GmbH is responsible for the construction, maintenance and equipping of railway networks. The Ludmilla, bearing the number 233 493-6, is also part of the large machine fleet consisting of approximately 400 vehicles. The "Tiger" locomotive supplies construction sites with work materials and devices.



PICTURE SHOWS HO-MODEL

Order no. **61048**      Order no. **61049** 

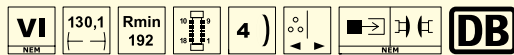

**Diesel Locomotive BR 233 DB AG, Bahnbau**  
Road no. 233 493-6

As a subsidiary of DB AG, DB Bahnbau Gruppe GmbH is responsible for the construction, maintenance and equipping of railway networks. The Ludmilla, bearing the number 233 493-6, is also part of the large machine fleet consisting of approximately 400 vehicles. The "Tiger" locomotive supplies construction sites with work materials and devices.



PICTURE SHOWS HO-MODEL

Order no. **61050**      Order no. **61051** 

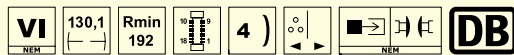

- With Next18 interface
- Rear signals
- Illuminated driver's cab
- True to original sound
- 5-pole motor
- All axles driven
- True-to-original speed
- Standard shaft to NEM 355
- Front light changes according to direction of travel
- Reproduction of cooling van
- Finely engraved details





**Passenger Coach BC4 SBB**  
Road no. 4951

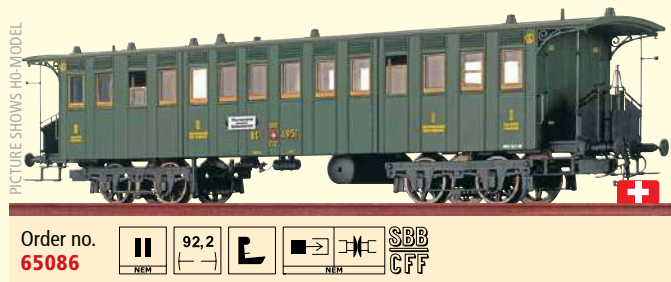

**Passenger Coach C4 SBB**  
Road no. 9301

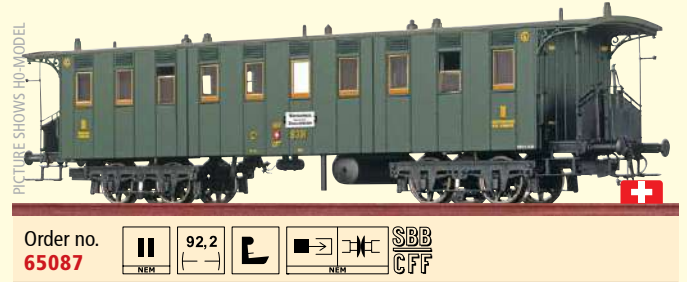

**Luggage Car F4 SBB**  
Road no. 18793

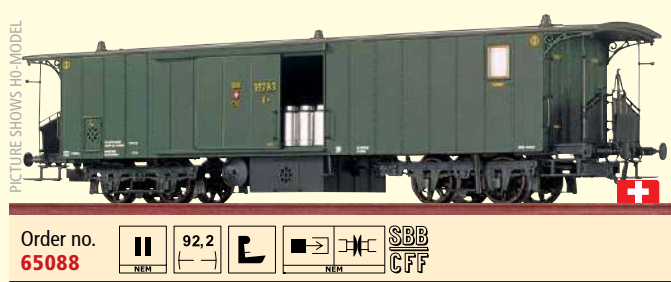

**Passenger Coach C4 SBB**  
Road no. 9410

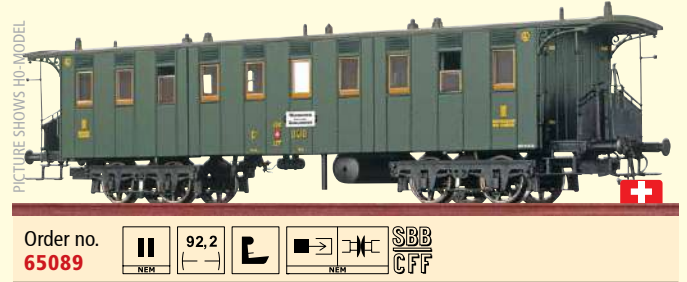

**Personnel Carrier SBB**  
Road no. 95 358

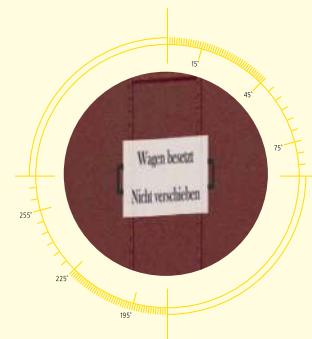
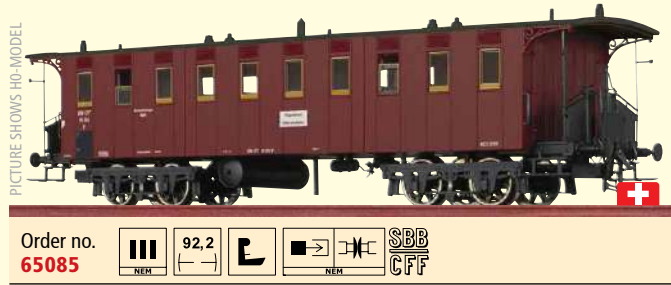



# TRADITIONAL BRANDS

LIMITED SPECIAL MODELS

For specialist dealers only available as a set. Available individually for end users.

Order no. **50936**



Order no. **50937**



Offer valid until sold out.

Subject to modifications in design and shape.  
Colour deviations are possible.

**Covered Freight Car G10 "Stihl" DB**  
Road no. 110 259



Order no.  
**49893**



**Covered Freight Car G10 "Würth" DB**  
Road no. 512 910 [P]

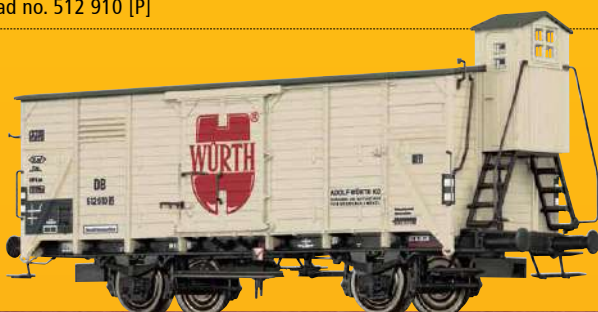

Order no.  
**50954**



**Covered Freight Car G10 "Quelle" DB**  
Road no. 521 810 [P]



Order no.  
**50955**



Covered Freight Car G10 "Krupp Stahl" DB  
Road no. 506 581 [P]



Order no.  
**50957**



Covered Freight Car G10 "Maico" DB  
Road no. 127 087



Order no.  
**50959**



Covered Freight Car G10 "Vorwerk" DB  
Road no. 129 407



Order no.  
**50960**



Covered Freight Car G10 "Fritz Homann" DB  
Road no. 133 309



Order no.  
**50961**



Covered Freight Car G10 "Kölner Kandis" DB  
Road no. 571 221 [P]



Order no.  
**50962**







# MILK CARS

LIMITED SPECIAL MODELS

For specialist dealers only available as a set. Available individually for end users.

Order no. **50946**  Order no. **50947** 

Offer valid until sold out.

Subject to modifications in design and shape.  
Colour deviations are possible.

Milk Car Gh03 "Bärenmarke" DB  
Road no. 102 111



Order no. **50977**  

Milk Car Gh03 "Molkerei Ammerländer" DB  
Road no. 105 743



Order no. **50979**  

Milk Car Gh03 "Südmilch" DB  
Road no. 106 156



Order no. **50980**  

Milk Car Gh03 "Schöller Eiskrem" DB  
Road no. 108 549



Order no. **50981**  





# AUTOMOTIVE BRANDS

LIMITED SPECIAL MODELS

For specialist dealers only available as a set. Available individually for end users.

Order no. **50942**

Order no. **50943**

Offer valid until sold out.

Subject to modifications in design and shape.  
Colour deviations are possible.

Covered Freight Car Glt "Audi" DRG  
Road no. Dresden 81 235



Order no.  
**50964**



Covered Freight Car Glt "DKW" DRG  
Road no. Dresden 81454



Order no.  
**50965**



Covered Freight Car Glt "Horch" DRG  
Road no. Dresden 81576



Order no.  
**50966**



Covered Freight Car Glt "Wanderer" DRG  
Road no. Dresden 81 811



Order no.  
**50967**



## Covered Freight Cars G10 "Beer Brands"

Covered Freight Car G10 "Sächsische Union Biere" DB  
Road no. 56-01-41 [P]



Order no. **50705**



Covered Freight Car G10 "Herrenhäuser" DB  
Road no. 564 839 [P]



Order no. **50986**



Covered Freight Car G10 "Spatenbräu München" DB  
Road no. 516 960 [P]



Order no. **50987**



FOR SPECIALIST DEALERS  
ONLY AVAILABLE AS SET

Order no. **50938**



Order no. **50939**



## Covered Freight Cars Tnf "Beer Brands"

Covered Freight Car Ibdlps<sup>383</sup> "König Pilsener" DB  
Road no. 502 527 [P]



Order no. **50982**



Covered Freight Car Tnfhs38 "Holsten" DB  
Road no. 579 013 [P]



Order no. **50983**



Covered Freight Car Tnfhs38 "Bitburger" DB  
Road no. 529 024 [P]



Order no. **50984**



FOR SPECIALIST DEALERS  
ONLY AVAILABLE AS SET

Order no. **50940**



Order no. **50941**



## Nostalgia of GDR

Covered Freight Car Gw "Deutrans" DR  
Road no. 21 50 112 3298-4



Order no. **50968**



Covered Freight Car G10 "Kloss & Foerster" K.P.E.V.  
Road no. Erfurt 602 302



Order no. **50969**



FOR SPECIALIST DEALERS  
ONLY AVAILABLE AS SET

Order no.  
**50944**



Order no.  
**50945**



Covered Freight Car G10 "Landskron Brauerei" DR  
Road no. 56-01-73 [P]



Order no. **50970**



## BRAWA Special Model "Easter"

Tank Car Z [P] 2-axle "Storck" DR Brit-US-Zone  
Road no. 586 289 [P]



*Pünktlich zu Ostern im Fachhandel erhältlich*  
*Available just in time for easter*



Order no.  
**50798**

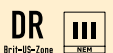

HO

## Skyline Ruhr Region – Limited Special Model

Covered Freight Car Ibs "Skyline Ruhr Region"

Road no. 21 80 805 1234-4



Order no. **50988**

## Skyline Vienna – Limited Special Model

Covered Freight Car Ibs "Skyline Vienna"

Road no. 21 81 943 2 841-3



Order no. **50989**







# THE NEW BRAWA WEBSITE IS ONLINE

MODERN LAYOUT  
AND EXTRA CONVENIENCE

Neu  
New

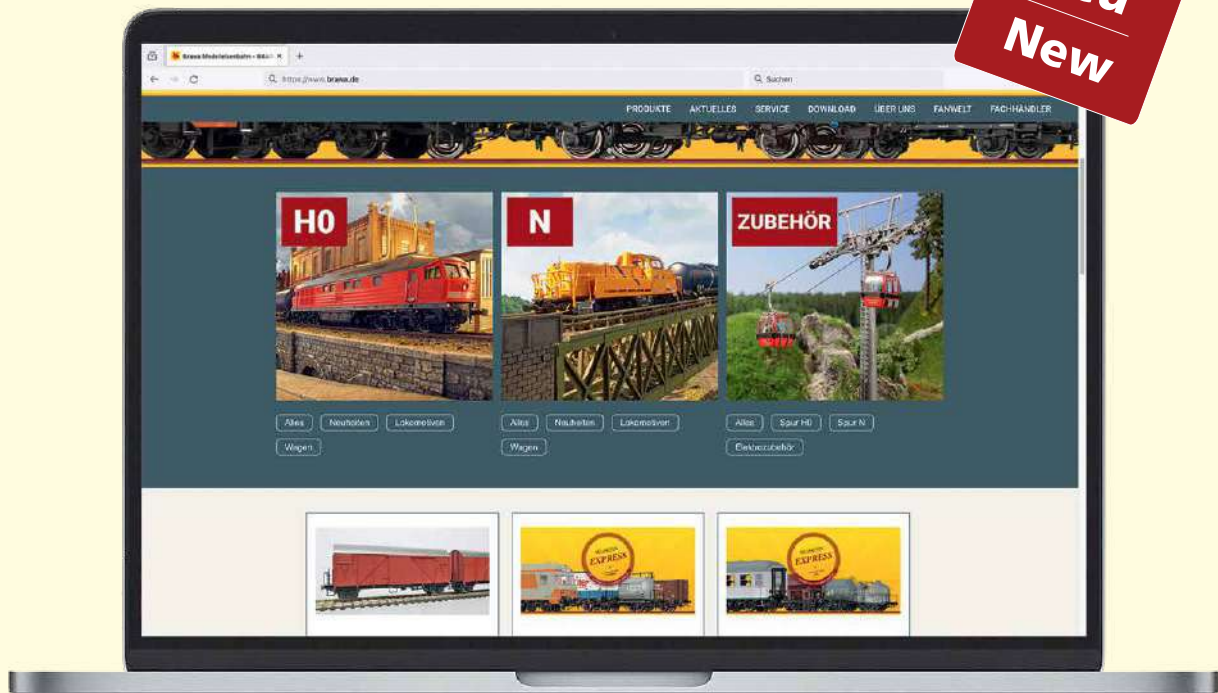

At the start of the new year, a completely revamped version of the BRAWA website went live, impressing users with its modern layout and even more user-friendly features. The newly structured homepage provides quick access to individual product groups, the latest updates, event notifications and direct links to essential customer service functions such as downloads, user manuals, sound files and the BRAWA repair and spare parts service.

The product configurator has been thoroughly revamped and now includes improved filtering options, making product selection even easier based on criteria such as era, railway company or country. The new website is also optimised for tablets and smartphones, offering

significantly improved loading times through the integration of new technologies. We hope you will enjoy discovering all these fascinating details.

[www.brawa.de](http://www.brawa.de)

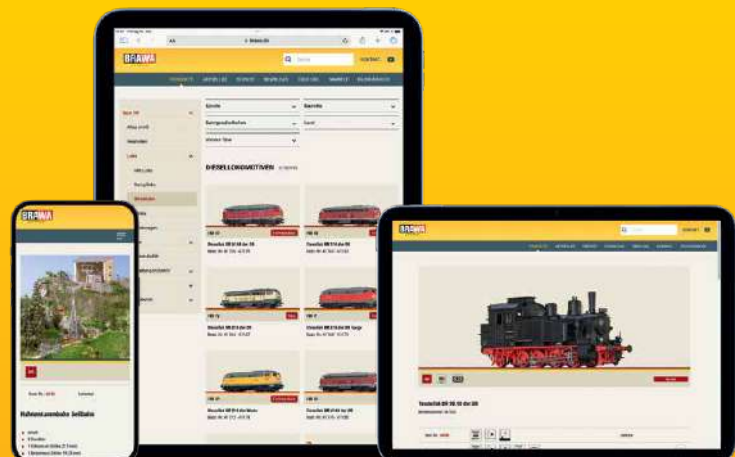



# BRAWA H0 WAGONS FOR ALTERNATING CURRENT CAN BE ORDERED DIRECT FROM THE FACTORY

FREE WHEEL SET REPLACEMENT BY BRAWA CUSTOMER SERVICE

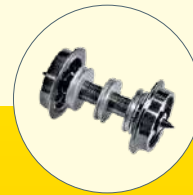

BRAWA locomotives and carriages can run on standard tracks with either direct and alternating current, giving model railway fans an even wider choice of exceptionally high-quality models.

The BRAWA H0 wagons come with DC wheel sets as standard. However, these models can also be obtained with wheel sets for alternating current – straight from the factory at no extra cost! You can easily pre-order the AC version of your chosen model via your specialist dealer. They will be equipped with AC wheel sets by BRAWA customer service and will arrive ready to run on AC tracks. Alternatively, a free wheel set replacement service is also available at your specialist dealer. You can find information about suitable replacement wheel sets for all H0 wagons in our brochures and on the BRAWA website.









BRAWA customer service in Remshalden





# THE SYMBOLS AND THEIR MEANING

 Era designation	 Navigable minimum radius in mm	 Digital Coupling	 Energy Storage
 Direct current Analog	 NEM 651 interface	 Functional, switchable fan	 The model has a coupler pocket but no short coupling cinematic
 Direct current Analog BASIC	 NEM 652 interface	 Locomotive has flywheel drive	 The model has a coupler pocket and short coupling cinematic
 Alternating current Analog BASIC+	 Interface with soldering points	 Double headlights alternating with the direction of travel	 The model has spring buffers
 Alternating current Digital	 Next 18 interface	 Double headlights and one red taillight alternating with the direction of travel	 With Replacement wheel set for AC
 Alternating current Digital EXTRA	 PluX22 interface	 Triple headlights alternating with the direction of travel	 Replacement wheel set for AC can be retrofitted (e.g. BRAWA product code 2180)
 Direct current Digital	 Number of wheels with friction tyres	 Triple headlights and two red taillights alternating with the direction of travel	 With AC pick-up
 Direct current Digital BASIC+	 Locomotive has a smoke generator	 Two red taillights	 AC pick-up can be retrofitted (e.g. BRAWA product code 2220)
 Direct current Digital EXTRA	 Locomotive is prepared for the installation of a smoke generator (e.g. Seuthe No. 20)	 With interior lighting	 Decoder Doehler & Haass
 Vehicle predominantly in metal	 Integrated sound	 Interior lighting can be retrofitted (e.g. BRAWA product code 2200)	 Logo of the railway company (e.g. DRG)
 Length over buffer in mm	 Prepared for sound	 With interior fittings	

Products modifications are possible after this brochure is printed. Subject to modifications in design and shape. Colour deviations are possible.

AEG, Alpirsbach, Ammoniakwerk Merseburg, APL / HANJIN, Aral, ATA, Audi, BASF, B.V. ARAL, Bärenmarke, Bitburger, BOB, Brauerei Aldersbach, CFL, CSD, D.A.P.G., DB AG, Deutrans, DKW, DSB, Farbenfabrik Wolfen, Fortschritt, Fritz Homann, FS, Gaffel Kölsch, GATX, Gräf & Stift, Gravita, Herrenhäuser, HOBUM, Holsten, Horch, Hugo Stinnes, IMI, Kali, Kloos & Förster, Kölner Kandise, König Pilsener, Konsum, Kronenbourg, Krupp Stahl, Kuba Imperial, Landskron Brauerei, Leuna, MAERSK / Hapag-Lloyd, Maico, Manner, Molkerei Ammerländer, NAH.SH, NS, ÖBB, OEVA, Ovomaltine, Persil, P.K.P., Quelle, Rail Cargo Austria, RheinCargo, Rekord Briketts, Sächsische Union Biere, Salmenbräu, SBB, SGL, SLM Winterthur, SNCF, SPA Monopole, Spatenbräu München, Städtische Häfen Hannover, Stihl, Storck, STRABAG, Südmilch, Südzucker, Texaco, Transthermos, TRAXX, Trebonske Pivovary, TWINDEXX Vario, VEB Farbenfabrik Wolfen, VEB Leuna-Werke, Vonwerk, VTG, Wanderer, Wiebe, Wifo Berlin, Winterthur and Würth are registered trademarks. The BP IN SHIELD is a trade mark and is used with the permission from BP p.l.c.. DHL® ist eine eingetragene Marke der DHL International GmbH. With authorisation SNCF-NMBS Train World Heritage. Schöller® is a registered trademark of Société des Produits Nestlé S.A.

# LIEBE ZUM DETAIL



FOR HEAVY FREIGHT CARS:  
FREIGHT LOCOMOTIVE BR 44 WITH OIL TENDER

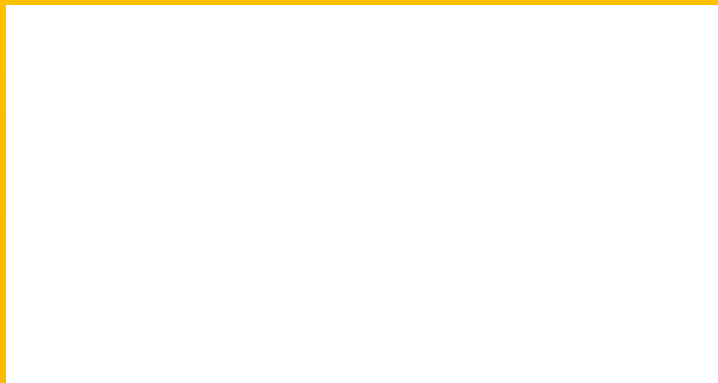

BRAWA Artur Braun Modellspielwarenfabrik GmbH & Co. KG . Uferstr. 24-30 . D-73630 Remshalden  
Hotline: Monday – Thursday: 1 p.m. to 3 p.m. . Phone +49 7151 97935-68  
Fax +49 7151 74662 . info@brawa.de . www.brawa.de



Order no. 0124.1